

We are IntechOpen, the world's leading publisher of Open Access books Built by scientists, for scientists

5,800

Open access books available

142,000

International authors and editors

180M

Downloads

Our authors are among the

154

Countries delivered to

TOP 1%

most cited scientists

12.2%

Contributors from top 500 universities



WEB OF SCIENCE™

Selection of our books indexed in the Book Citation Index
in Web of Science™ Core Collection (BKCI)

Interested in publishing with us?
Contact book.department@intechopen.com

Numbers displayed above are based on latest data collected.
For more information visit www.intechopen.com



Chapter

Overview of Noise Control Techniques and Methods

Alice Elizabeth González

Abstract

Noise control refers to a set of methods, techniques, and technologies that allows obtaining acceptable noise levels in a given place, according to economic and operational considerations. The question of “acceptance” is for what or for whom. Generally, there is no single answer to this question, nor is there a single solution to any given problem, as long as regulatory compliance is achieved. Noise control does not necessarily imply the reduction of noise emissions—it refers to making acceptable sound pressure levels of immission (i.e., the signal reaching the receiver). This chapter aims to present the basis of noise control techniques, both in emission and propagation, to finally achieve the most current protection techniques for the receivers, when there are no more alternatives in the previous steps.

Keywords: noise control, silencers, acoustic barriers, green barriers, active noise control

1. Introduction

When faced with a situation in which the sound pressure levels (SPL) are too high according to the intended use of a certain place, there are several options for enhancing its acoustic quality. Noise control solutions can be passive or active. Passive control is the most used solution; it aims to dissipate the excess acoustic energy through absorption, transmission, or diffusion. On the other hand, active noise control (ANC) solutions imply introducing a specific acoustic signal to counteract the sound waves to be controlled. As in most environmental issues, the possible measures must be analyzed seeking first to improve the performance of the source, that is, to reduce its emissions; then the possibilities of acting on the propagation path are to be studied; taking protection measures at the potentially affected receivers will be considered only as a last option for noise control.

Even with the latest technology to meet a requirement or to satisfy an objective, noise emissions can occur due to friction, impact, turbulence, imbalance of moving parts, and cavitation in fluids, among many other causes. In addition, the lack of maintenance or operating in an incorrect manner can increase noise emissions. Measures in the propagation pathway become necessary in many cases, for example, when working with high-power or high-speed machinery. The most common options are silencers, either reactive or dissipative; plenum chambers; acoustic coatings; enclosures; noise barriers; vibration dumping or insulation. When reducing the sound

pressure levels at the receiver is still needed, the use of personal hearing protection is considered, although sometimes control booths or cabins can be very good options.

First, having an accurate diagnosis of the problem is essential. Some issues that should be considered before making a decision are ventilation requirements of the equipment; characteristics of location; availability of space; energy requirements; operation and maintenance; and costs.

This chapter presents the main features of passive control systems, which are usually the most common; and then, ANC solutions, which have various applications, especially for low-frequency noise.

2. Passive noise control

Passive noise control includes a wide set of techniques aimed to make the immission sound pressure level admissible to the receivers.

There are some general measures that can make a difference. They are low cost and based on common sense. It is rather common to find these improvement opportunities, for example, rearranging the work process to avoid unnecessary exposure to high noise levels to the public, changing the direction of loudspeakers at music venues, or encouraging the public to disperse at the end of recreation activities.

There is a wide spectrum of control measures to be considered, depending on the type of source. The sooner control measures are taken, the faster the results.

2.1 Engines noise control

Periodic preventive maintenance of devices, engine mobile parts, and machinery is essential—checking the condition of gears, bearings, and proper lubrication.

Noise emitted from internal combustion engines is the result of airflow processes into the engine (aerodynamic noise), from the mechanical movement of the engine (mechanical noise), and from pressure increases associated with the combustion process (combustion noise). Combustion noise is normally the predominant source in diesel engines, due to the rapid rise of pressure inside the cylinders. The noise emitted by a combustion engine is related to the efficiency of conversion of chemical energy into mechanical energy; the acoustic energy related to the roar of the engine is usually between 10^{-8} and 10^{-5} of its power. For two devices of the same power, the noise emitted by a diesel generator is greater than the one emitted by a natural gas one [1].

The acoustic power of engines is related to their maintenance—acoustic emissions are an indicator of waste of energy. For continuous combustion systems, the combustion noise can be expressed in terms of the thermo-acoustic efficiency, which is the ratio between the total energy of a sound pulse and the heat release rate. An engine in good operating conditions should normally emit between 10^{-6} and 10^{-5} of its power through acoustic energy; if the system is in improper condition, the acoustic emissions could rise to 10^{-4} of its thermal power [2]. The maximum thermo-acoustic efficiency expected for unconfined hydrocarbon flames is 10^{-6} . When a combustion engine is not in proper operating conditions, the frequencies that denote higher sound pressure levels are the harmonics of the rotational frequency. This also happens in other rotating or reciprocating machines. Malfunctions in electric motors are usually related to excessive noise in harmonics of the synchronous frequency. In other electrical devices, the noise appears in harmonics of the line frequency. A catalog of engine problems and the frequencies where they appear is presented in Ref. [3].

Heat recovery boilers are recommended as noise control devices for large engines. They act as passive silencers, but when installed, of course, they can provide other services too (e.g., heating for decreasing the fuel viscosity).

A heat recovery steam generator performs “a secondary function as an in-line silencer for combustion turbine noise emissions” [4]. The recovery boiler can be considered part of the noise emission control system to comply with the immission level regulations. Hence, it must be specified as such.

Sometimes dedicated passive silencers can be avoided by the installation of recovery boilers with a secondary function as exhaust silencers. **Table 1** presents the reduction in SPL measured between up-flow and down-flow of a recovery boiler. The reduction is from 10 dB (at 125 Hz) to 35 dB (at 8000 Hz). The reduction in A-weighted SPL is also high: 25 dB [5].

2.2 Passive silencers

Passive systems, whose generic designation is silencers, can act either through their geometric characteristics or through the incorporation of acoustic absorbent materials. According to their principle of action, silencers can be classified into two families: reactive or reflective silencers and dissipative or resistive silencers.

2.2.1 Reactive or reflective silencers

The principle operation of reactive silencers is based on generating sound reflections from geometric properties of the propagation medium, for example, section changes. They are usually solved with coupled tubes. **Figure 1** shows a sketch of a reactive silencer; how to calculate its transmission loss (TL) is also presented.

For a discontinuous area reactive silencer as sketched:

When an acoustic wave of amplitude A_i propagates with velocity v_1 in a tube of section S_1 and it changes abruptly to a section S_2 , a reflected wave of amplitude A_r goes back to the source and a transmitted wave of amplitude A_t continues propagating with velocity v_2 . According to Snell’s Law, the amplitudes of these waves (A_r and A_t) can be written as ([6]):

$$A_t = \frac{2 v_2}{v_1 + v_2} A_i; A_r = \frac{v_2 - v_1}{v_1 + v_2} A_i \quad (1)$$

f (Hz)	63	125	250	500	1000	2000	4000	8000	A-weighted
Reduction (dB)	11	10	18	25	28	26	31	35	25

Table 1.
 SPL reduction achieved by a recovery boiler in a paper mill (from Ref. [5]).

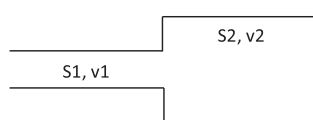

For a discontinuous area reactive silencer as sketched:

$$TL = 10 \log \left[\frac{(S_1 + S_2)^2}{4 S_1 S_2} \right]$$

Figure 1.
 Sketch of operation principles of reactive silencers (adapted from Ref. [7]).

The greater the difference between S_1 and S_2 , the better attenuation is obtained; the shorter the transition between S_1 and S_2 , the better attenuation is also obtained. According to Ref. [6], the SPL reduction in an abrupt expansion as sketched in **Figure 1** could be between 2 dB (for $S_2/S_1 = 4$) to more than 8 dB (for $S_2/S_1 = 25$).

These silencers do not require absorbent materials. Their best application is to control narrow band noise or tones at discrete frequencies, especially low frequencies. The most common designs are sketched in **Table 2**. The highest frequency of plane (or bidimensional) waves to be controlled by this type of silencer can be estimated as [6]: $f < c/2a$, where c is the velocity of sound and a is the diameter of the tube, or the minor dimension of its section if it is rectangular. It is important to consider that the wavelength λ of the waves to be controlled should also satisfy: $\lambda \ll a$.

Also, the well-known Helmholtz resonator can be designed to serve as a silencer, for example, mounting a Helmholtz device designed according to the frequencies to control one side of the tube/duct, where the noise control is needed. A reduction up to 8 dB can be obtained [7]. The volume V of the cavity and the radio r and length l of the neck are to be determined according to the frequency f to control, using the equation of the resonance frequency of a Helmholtz presented in **Figure 2**.

2.2.2 Resistive or dissipative silencers

These are the most suitable silencers to control medium and high frequencies sectors of the broadband noise spectrum. These consist of devices coated with a porous acoustic absorbing material, in contact with the airflow where noise control is needed. The most usual acoustic absorbing materials for the coats are mineral wool or fiberglass. Their effectiveness is based on dissipating the acoustic energy of sound waves as heat, by forcing the flow to lose its energy through friction.

The performance of acoustic dissipative silencers depends on the features of the coating, the thickness and length of the acoustic absorbing materials, the features of

	<p>Expansion chamber:</p> $TL = 10 \log \left[1 + \left(\frac{S_1^2 - S_2^2}{2S_1 S_2} \right)^2 \cdot \text{sen}^2 \left(\frac{2\pi l}{\lambda} \right) \right]$
	<p>Side branch reactive silencer:</p> $TL = 10 \log \left[\frac{S_1 \cdot S_2 \cdot (S_1 + S_2)}{4} \right]$

Table 2.
Sketch and TL of two designs of reactive silencers (adapted from Ref. [7]).

	$f = \frac{c}{2\pi} \sqrt{\frac{S}{V l_e}}$ <p>S is the area of the cross section of the neck l_e is the effective length of the neck: $l_e = l + 1,7 r$</p>
--	--

Figure 2.
Sketch of a side Helmholtz silencer (adapted from Ref. [6]).

the flow passage section, and the pressure drop in the system (remember that the pressure drop is proportional to the squared velocity of the flow u^2).

2.3 Encapsulations

Encapsulations can be suitable options for noise control for many types of equipment. The most used enclosures are small buildings where the noisy machines are enclosed. They must be designed by taking into account not only the acoustic characteristics but the ventilation needed for proper operation. Even when each machine complies with noise emission standards, the need of reducing SPL in areas close to public or private works is a major concern. Giraldo Arango states that “Empresas Públicas de Medellín E.S.P.” (Public Companies of Medellín, Colombia) successfully incorporated some environmental management requirements in its work specification, especially for Public Works [8]:

... the use of modern machinery and equipment with soundproofed engines; preventive and corrective maintenance measures must be taken to keep equipment in proper working conditions; if not possible to insulate the sound emission of, that is, jackhammers or disc cutters, then a maximum of two continued hours of noisy equipment operation should be taken, with breaks of the same duration; coordinating and scheduling with authorities of schools and health institutions, in order to conduct noisy operations during class breaks or shift changes ...

He also states: “... people from public and private sectors mention it is not possible to control noise. ... it has been proven that it is possible in practice by using other methods as those normally used, and which are environmentally and economically more attractive.” In his opinion, stricter control of environmental management is needed; control activities should be handled by the contractor [8].

Some machines have the possibility of building a customized enclosure, either removable or fixed. They must have both good acoustic insulation and absorption properties. **Table 3** presents the comparison of the SPL measured at 1 m from two twin well-point pumps [9]. One of them was enclosed in a customized acoustic removable capsule. Both measurements were done with a class 1 sound level meter during the same morning when the pumps were working in similar conditions in the same area of the city. Drastic reduction in the values of some parameters was experienced for A-weighted sound pressure levels.

2.4 Traffic noise control: special pavements

The noise of road vehicles is generated from three main sources—engine acoustic emissions, which represent the main source at low velocity; tire-pavement noise, which is dominant from 60 to 100 km/h (approximately); and aerodynamic noise, which is more significant at high speeds (greater than 100 km/h).

Acoustic pavements are designed for reducing noise due to contact with the tires. They have a high sound absorption coefficient in the frequency range where rolling emissions are greater. Thus, the acoustic energy is dissipated as heat, rather than reflected on the ground. Smooth pavements will be less noisy at high speeds if they are dry; in wet conditions, an increase of about 4 dB can occur.

There are different responses of pavements according to the frequency. The results depend on the mass percentage of the asphalt, the air pockets in mineral aggregates, and

	Non-enclosed machine	Enclosed machine	Difference	Observations
L_{AFmax}	87.2	77.1	-10.1	Significant attenuation
L_{AFmin}	82.6	74.3	-8.3	Significant attenuation
$L_{A_{Ieq}}$	86.4	76.4	-10.0	Significant attenuation
$L_{A_{Feq}}$	84.8	75.5	-9.3	Significant attenuation
$L_{C_{Feq}}$	91.1	90.2	-0.9	As expected, the enclosure is not effective at low frequencies
L_{AF10}	85.4	75.9	-9.5	Significant attenuation
L_{AF50}	84.8	75.5	-9.3	Significant attenuation
L_{AF90}	84.1	75.1	-9.0	Significant attenuation
$L_{A_{Ieq}} - L_{A_{Feq}}$	1.6	1.0	-0.6	As $L_{A_{Feq}}$ and $L_{A_{Ieq}}$ present similar decreases, significant changes none were found
$L_{C_{Feq}} - L_{A_{Feq}}$	6.3	14.8	+8.5	Due to the ineffectiveness of the enclosure at low frequencies, $L_{C_{Feq}}$ does not change significantly, while $L_{A_{Feq}}$ does. Hence, the difference $L_{C_{Feq}} - L_{A_{Feq}}$ raises
$L_{AF10} - L_{AF90}$	1.3	0.8	-0.5	As L_{AF10} and L_{AF90} present similar decreases, significant changes none were found

L_{AFmax} = A-weighted maximum sound pressure level, measured in fast time weighting; L_{AFmin} = A-weighted minimum sound pressure level, measured in fast time weighting; $L_{A_{Ieq}}$ = A-weighted equivalent sound pressure level, measured in impulse time weighting; $L_{A_{Feq}}$ = A-weighted equivalent sound pressure level, measured in fast time weighting; $L_{C_{Feq}}$ = C-weighted equivalent sound pressure level, measured in fast time weighting; L_{AF10} = A-weighted 10% exceedance sound pressure level, measured in fast time weighting; L_{AF50} = A-weighted 50% exceedance sound pressure level, measured in fast time weighting; L_{AF90} = A-weighted 90% exceedance sound pressure level, measured in fast time weighting.

Table 3.

Comparison of the acoustic performances of two well-point pumps, one of them into a customized acoustic enclosure (from Ref. [9]).

the aggregates grading curve [10]. The most silent pavements are the so-called draining or porous pavements. They can reduce up to 5 dB, especially in high frequencies. They have a very high percentage of holes in their structure, which absorb part of the sound energy emitted by vehicles (both by the tires and by the engine) and drain rainwater as well. The high porosity is obtained by using uniform-sized aggregates.

Acoustic pavements are not only expensive but also they age as their pores clog; then, they lose their acoustic properties. Highways and high-speed roads are less vulnerable to aging, due to a self-cleaning effect caused by the movement of vehicles at high speeds. In urban areas where circulation speeds are slower, permeability is quickly lost. The cleaning procedures are expensive, difficult and of limited efficiency, so the construction of these special pavements is restricted to high-speed traffic lanes.

There are currently promising developments in acoustic pavements that use reclaimed materials. The aging phenomenon was studied at three pavement sections of rubberized asphalt (i.e., asphalt containing crumb rubber from tires) [11]. The best analytic relation to link acoustic properties and aging is not linear but logarithmic. The main variables that correlate in a direct sense are the temperature of air and pavement, and the hardness of the rubber of the tires; an inverse relation was found with other variables, such as heavy traffic flow, age of the pavement, and climate variables [11].

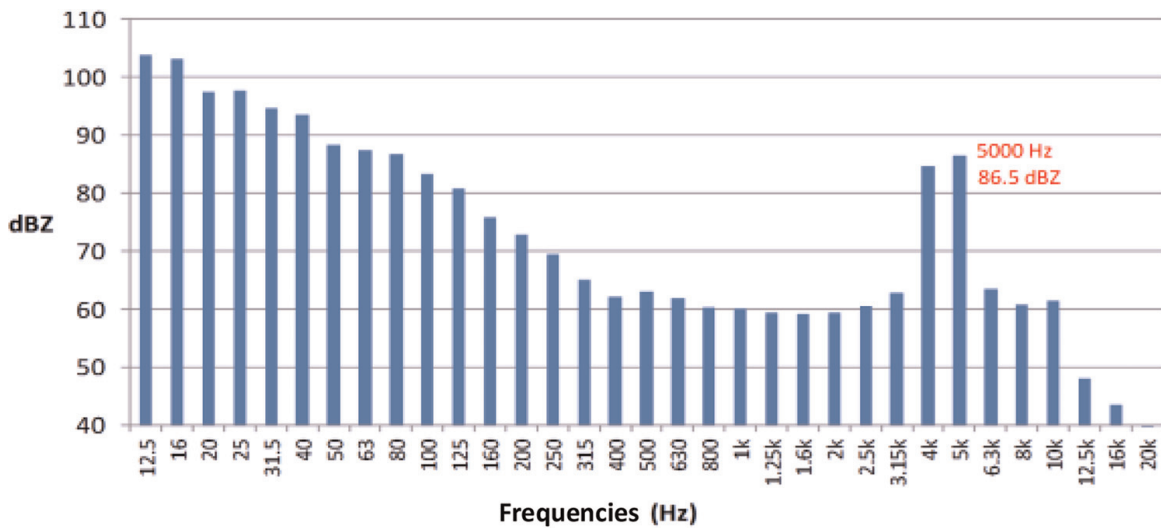

Figure 3. Measured sound pressure level spectrum of a wind-induced annoying noise caused by airflow through small holes (from Ref. [12]).

2.5 Aerodynamic noise

The interaction between wind and constructions can produce acoustic emissions. Sometimes they are caused by the detachment of the boundary layer developed on a surface, for example, the blades of a wind turbine, the hood of a vehicle, or the wings of an aircraft. The use of a slitted-sawtooth serrated trailing edge to control the trailing edge noise in large wind turbines reduces SPL by about 5 dB [13]. When the noise is related to the airflow through holes or slots, the noise spectrum usually presents strong pure tones, as shown in **Figure 3**.

The emission of noise can be related to a constriction in the flow that causes an increase in the velocity of the airflow; it is the case of the passage of air through holes, slots, or openings that are part of the design of a building. Analyzing the geometry of the problem and the statistics of wind velocity and direction, the most suitable solutions for preventing the phenomenon are—modifying the dimensions of holes and slots; selectively blocking or covering the openings [14]; or modifying the geometry of the wind passage to act on the degree of turbulence of the incoming flow [12].

3. Passive noise control along the propagation path

The intensity of a sound wave is the acoustic energy carried by the wave per unit of area and per unit of time. It can be computed as the relation between the squared sound pressure and the acoustic impedance of the propagation medium. Thus, two possible ways to reduce the sound intensity are acting directly on the sound pressure or acting on the acoustic impedance along the propagation path.

3.1 Changes in acoustic impedance along noise path

A change in the acoustic impedance Z along the sound path imposes a modification on the sound wave amplitude. When a sound wave intends to pass from a propagation medium 1 with acoustic impedance Z_1 to another medium 2 with acoustic impedance

Z_2 , the fraction of its intensity transmitted from **1** to **2** is determined by the transmission factor F_t . The non-transmitted energy goes back to medium **1**, according to the reflection factor F_r . These factors can be written as relations between Z_1 and Z_2 [6]:

$$F_t = \frac{4 Z_1 Z_2}{(Z_1 + Z_2)^2}; F_r = \left(\frac{Z_1 - Z_2}{Z_1 + Z_2} \right)^2 \text{ with } F_t + F_r = 1 \quad (2)$$

If Z_1 and Z_2 have close values, F_r will approach to zero and most of the acoustic energy will be transmitted. If Z_1 and Z_2 are very different, most of the acoustic energy will be reflected. Generalizing, a large difference between the impedances of the two media reduces the transmitted acoustic energy. Then, when passing from **1** to **2**, most of the acoustic energy will not be transmitted and the same will occur when passing back from **2** to **1**. This principle is used for the design of composite materials for acoustic insulation, but it is also suitable for controlling solid-induced noise and vibrations. In the first case, the best materials for acoustic insulation of airborne noise are those with very high acoustic impedance, because the acoustic impedance of the air has a low value (around 415 rayl).

When vibrations and/or solid-induced noise are to be controlled, one of the preferred solutions is “cutting” the propagation path and filling the joint with a soft material whose acoustic impedance value is as far as possible from that of the transmission medium. It is a common solution when building double walls to have independent foundations, but also the principle of floating floors and a good option for damping/insulating floor- or wall-transmitted vibrations.

Table 4 presents the value of longitudinal sound velocity, density, and acoustic impedance for some materials, including some types of common polymers.

3.2 Acoustic barriers or screens

The main parameter to describe the performance of acoustic barriers is the insertion loss (IL), which represents the difference between the SPL at a receiver without and with the barrier. The maximum value of IL that can be theoretically achieved is 20 dBA for thin screens and 23 dBA for earth embankments [15].

3.2.1 How does an acoustic barrier work?

An acoustic barrier or screen consists of an obstacle—usually, similar to a wall—that stands between a sound source and a receiver, and whose characteristics are defined to acoustically protect the receiver. The length of the screen normal to the source-receiver line may be greater than the wavelength for which the barrier is designed. Acoustic barriers aim to create a relatively calm and silent space behind it, in the so-called “acoustic shadow area,” even at a short distance from any relevant sound source. The most frequent applications of acoustic barriers are concentrated around highways and railways, in construction sites and mining areas, in the vicinities of airports and industrial zones. They may be placed as close to the source as possible, to maximize their performance. Even though, sometimes it is necessary to put them close to the neighborhoods to protect them against the noise from different sources.

Four types of phenomena occur in an acoustic barrier: reflection, absorption, refraction, and diffraction (**Figure 4**).

Medium	Sound velocity c [m/s]	Density ρ [kg/m ³]	Acoustic impedance Z [rayl]
Aluminum	6300	2700	16.8×10^6
Bone	4080	1900	7.7×10^6
Brick	4300	1700	7.3×10^6
Cellulose butyrate	2140	1190	2.55×10^6
Clay	3400	2600	8.84×10^6
Concrete	3500	2600	8.9×10^6
Dry sand	1700	1610	2.74×10^6
Ethyl vinyl acetate (EVA)	1800	94	0.17×10^6
HDPE plate	2570	950	2.4×10^6
Iron	5900	7690	46×10^6
Iron cast	4600	7220	33.2×10^6
LDPE plate black	2180	915	1.9×10^6
Lead	1190	11,300	13.5×10^6
Marble	3810	2800	10.5×10^6
Neoprene	1600	1310	2.1×10^6
Nylon (polyamide)	2710	1150	3.1×10^6
Paraffin	1940	910	1.76×10^6
Polymethylmethacrylate (PMMA)	2724	1180	3.2×10^6
Polycarbonate	2250	1210	2.77×10^6
Polyester casting resin	2290	1070	2.5×10^6
Polyoxymethylene (POM)	2430	1420	3.45×10^6
Polypropylene	2470	880	2.2×10^6
Polystyrene rexolite	2346	1040	2.3×10^6
Polyurethane elastomers	1700	1040	1.80×10^6
Polytetrafluoroethylene (PTFE)	1530	2200	3.4×10^6
(PVC)	2380	1380	2.9×10^6
Recycled plastic	857	940	0.8×10^6
Rubber-like material	1300–1700	900–1300	$(1.2–2.2) \times 10^6$
Stainless steel	5800	7930	46×10^6
Tin	3300	7300	24.2×10^6
Vinyl rigid	2230	1330	2.96×10^6
Wood	4000	700	2.8×10^6
Wood cork	500	250	0.12×10^6
Zinc	4200	7000	29.4×10^6

Table 4.
 Acoustic properties of some materials (values from various sources).

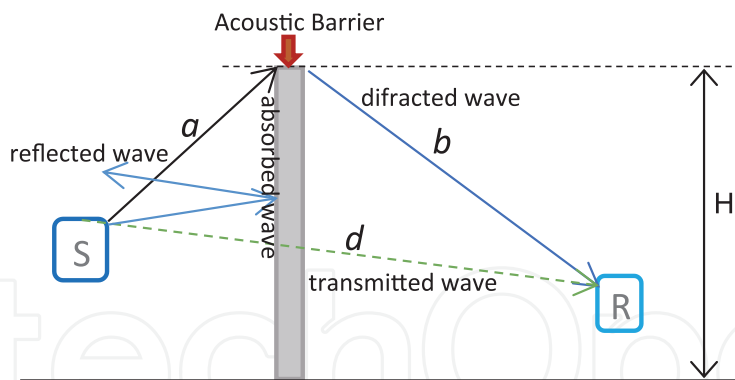

Figure 4. Acoustic phenomena that occur in a barrier (adapted from Ref. [16]).

Reflection and refraction follow Snell's law; the fraction of the acoustic energy that will be refracted and reflected can be estimated with the coefficients F_r and F_t presented in the previous section. Please consider that the refracted energy involves both the transmitted and the absorbed at the surface of the screen, that is, the refracted energy is all the energy that is not reflected.

The requirements for the materials for building acoustic barriers are not acoustically challenging: a minimum surface density of 10 kg/m^2 is sufficient to obtain an adequate transmission loss (TL) value. Tightness is important: a percentage of openings of more than 1.5% in the screen surface causes a reduction of 3 dB in its transmission loss TL.

The most important feature to consider for designing a noise barrier is diffraction. Both the upper and the side edges of a noise barrier become diffracted noise sources. Hence, for calculating the SPL at a receiver without the direct vision of the main noise source, the contributions of each one of these new sources are to be added. If the barrier has a special heading, its reduction may be also considered.

A barrier can be considered thin or thick. A thin barrier can be thought of as a flat surface with mass but without thickness; thus, its edges would act as lines where diffraction can occur. An acoustic barrier is said to be thick when it has more than one point where diffraction can occur. The most frequent case is that of embankments, although the buildings of a city are very important to control noise pollution, as they have many edges for diffraction.

When the wavelength to be controlled is less than 20% of the top width ($\lambda < e/5$), the barrier will be considered thick. If the top width exceeds 3 m, the barrier will behave as thick for all frequencies. Otherwise, the barrier will behave as it is thin and it should be designed in such a way. In the case of thick screens, the thickness e may be added to the smallest distance a or b (Figure 5) to get the new values a' or b' . All calculations may be computed using the new values a' or b' .

A thin barrier can turn into a thick one simply by adding a proper header for having multi-edge diffraction and enhancing its performance and effectiveness. Using absorbing materials on the surface exposed to the noise source is not mandatory; nevertheless, it can be useful for reducing noise reflections, that is, when there are screens on both sides of a highway or railway.

The best geometry for using absorbing materials is when the height H of the screen is greater than 20% of its length L ($H > L/5$). In addition, the best solution for avoiding reflections when $L/10 > H > L/20$, is by positioning one of the two screens at a minimum angle of 15° vertical. When $L/5 > H > L/10$, cases should be studied individually. If $H < L/20$, no simple action will significantly improve its performance

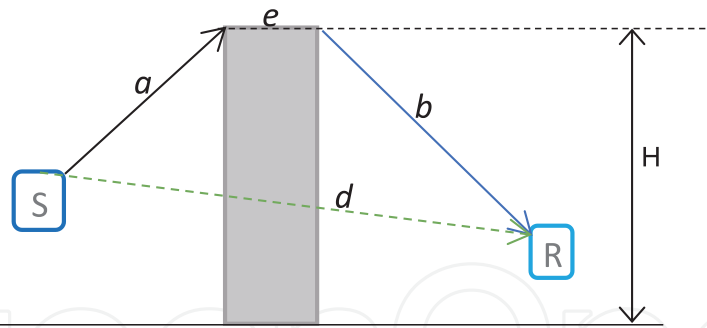

Figure 5.
Cross section of a thick screen (adapted from Ref. [17]).

[18]. Many natural fibers can contribute to acoustic absorption; the best performance was achieved by fibers, such as kapok, pineapple-leaf, and hemp [19].

Substituting a reflective barrier placed 1 m far from a railway with an absorptive one could improve IL up to 6–10 dB [20]. Placing a Schroeder diffuser on the surface of an extruded-PVC acoustic barrier could improve the IL in almost all frequencies between 315 Hz and 8000 Hz [21].

When a transparent or a reflective material is selected for a noise barrier, the birds will not be able to visually recognize it. Thus, to minimize bird collisions onto barriers, the use of opaque stripes or dots should be taken into account in the terms of reference [22]. The old usage of painting raptors onto transparent barriers [20] can also be substituted with an ultraviolet “A” reflecting coating (UV-A), that is visible only to birds.

3.2.2 Types of acoustic barriers

When selecting the type of acoustic barrier to construct, not only the acoustic performance must be taken into account, but also the available space, characteristics of topsoil and subsoil conditions, the possibilities of landscaping integration, and the cost per m or per km, both for construction/mounting and maintenance.

The most common types of barriers are thin screens, soil embankments, partitions or enclosures, and green curtains:

- **Thin screens:** They are relatively thin constructions for controlling noise in the vicinity of roads or railways. Their IL strongly depends on their height, length, and materials. Thin screens can be built of concrete, absorbent bricks, galvanized steel, wood, wood panels, aluminum, methacrylate, and polycarbonate, among others.
- **Soil embankments:** They are mounds that are usually covered with grass. They usually have a good acceptance. Their main disadvantages are the need for huge space for their construction and constant maintenance. Nevertheless, when there is enough space and proper materials for its construction, it is a rather economical solution. The IL should be calculated as a multiple-diffraction screen (thick barrier). It should be noted that the height of a ground embankment used as an acoustic barrier should be higher than a thin barrier to achieve the same results.
- **Partitions or enclosures:** They are partial or total covers of a route or street section, to avoid noise propagation. They are very effective, but their construction and maintenance can be very costly.

- Green barriers: They produce the best esthetic result. On the other hand, their acoustic performance is poor and they need constant maintenance.

Both thin and green barriers can be designed as modular infrastructure, to build different configurations [23]. The “A-frames” built out of Corten steel facilitate plants growth, protection, irrigation, and maintenance [20].

The costs of different materials of noise barriers by life-cycle cost analysis are compared in Ref. [24]. The present net worth is considered by adding the initial construction cost and the annual cost of maintenance and replacement during a life of n years, with an interest rate i of 5.5%. The service life of embankments and concrete is considered of $n = 50$ years, and of $n = 25$ years for steel-, wood- and aluminum-based materials. In this framework, the most cost-efficient option was earth embankments; the least cost-efficient was the aluminum-based materials (four times more expensive than earth embankments).

3.2.3 Basic acoustic design of an infinite acoustic barrier

Although there are several explicit calculation methods, they are only approximations. If an accurate value is needed, applying numerical modeling techniques is mandatory. Possibly, one of the earliest methods to calculate the IL of an acoustic barrier is Maekawa's [20]. It considers frequencies between 100 Hz and 5000 Hz. The depletion of SPL due to diffraction on the top edge can be calculated as $IL = 10 \log(20 N)$.

N is the Fresnel number and it can be obtained with basis on the wavelength λ and the difference between the direct path d (the geometric distance between source and receiver) and the path over the barrier, or diffracted path ($a + b$), as indicated in **Figure 4**:

$$N = \frac{2}{\lambda} (a + b - d) = \frac{2\delta}{\lambda} \quad (3)$$

Best results of Maekawa's expression are obtained when the height of the barrier is significantly less than its length, a is less than 5 m, the height of the source is greater than a and the height of the receiver is greater than b .

Other expressions for estimating IL are in use, aiming to improve the accuracy of the results [20, 25]:

- For point sources: $IL = 10 \log(3 + 20 N)$ with $N > 1$.
- For linear sources and traffic noise: $IL = 10 \log(2 + 5.5 N)$ with $N > 1$.

Kurze-Anderson [20]:

$$\Delta L = IL = 20 \log \frac{\sqrt{2\pi N}}{\tanh \sqrt{2\pi N}} + 5 \text{ for } -0.2 < N < 12.5 \quad (4)$$

or $\Delta L = IL = 24$ dB for $N > 12.5$ (only for point source).

Taking into account that $\tanh X = \frac{\sinh X}{\cosh X} = \frac{e^X - e^{-X}}{e^X + e^{-X}}$.

When ground absorption is to be considered, please use the next expression, either for thin or thick barriers:

$$IL = 10 \log (3 + 10 N K) - A_{ground} \quad (5)$$

The ground absorption A_{ground} can be computed by any proper method.

The value of K is related to meteorological conditions, according to:

When $100 \text{ m} < a + b < 300 \text{ m}$: $K = e^{-0.0005 \sqrt{\frac{abd}{N\lambda}}}$; otherwise, $K = 1$

Pita Olalla [26] proposes the following expression for a linear source:

$$IL = \Delta L = 15 \log \frac{\sqrt{2\pi N}}{\tanh \sqrt{2\pi N}} + 5 - 10 \log (2e^{-h/2\lambda} + 1) \quad (6)$$

where h = height of the acoustic barrier.

3.2.4 Minimum length of a noise barrier

To calculate the minimum length of a barrier, the most important variable is the angle of view of the receiver (**Figure 6**). If the angles of view of the receiver are α and β , the acoustic energy that can reach it will be proportional to the ratio between $(\alpha + \beta)$ and the straight angle of which they are part. Thus, if the receiver is located at a distance d from the road, the expected sound pressure level at its location will be [18]:

$$L_{p,d} = L_d - IL + 10 \log \frac{180^\circ - (\alpha + \beta)}{180^\circ} \quad (7)$$

where $L_{p,d}$ is the SPL at distance d from the source, with the screen; L_d is the SPL at the same point, without the screen; IL insertion loss of the noise barrier, if infinite; and α, β are the angles of direct view of the source from the receiver, at both sides of the screen.

The relation between the IL and the shielding angle from the receiver does not depend on the distance from the receiver to the barrier, as stated by Ross et al. [27] after analyzing a set of 300 sites with barriers from 90 to 1100 m in length. When studying the behavior of barriers of the same length and different heights, the shielding angle should be at least 165° to reach a good IL value. The effectiveness of the barrier will have an abrupt depletion if the shielding angle is less than 140° . These results backup the usual recommendation of having a shielding angle of at least 160° , which is rather the same as having a barrier length of at least four times the distance d on each side of the receiver to be protected. (Strictly, the value should be closer to l between $6-7.5d$).

3.2.5 Headers or cappings

While the basic design of a noise barrier involves defining the location, height, and materials of a wall with a horizontal top edge, there are many possible designs for capping the wall. Headers or cappings are very important in the acoustic performance of barriers. Although they also have an esthetic function, headers seek to improve

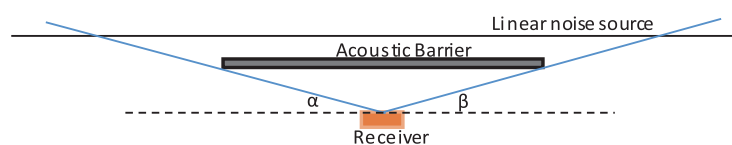

Figure 6. Sketch for calculating the length of an acoustic screen (adapted from Ref. [18]).

noise reduction achieved by diffraction at the upper edge of the screen. There are cantilevered cappings, multi-diffraction, tubular, Y-shaped, absorptive or reflective ones, designs for promoting destructive interference, sound diffusion or scattering. There are even patented acoustic header designs for acoustic barriers. A broad catalog of tested header designs can be found in Ref. [26]. The excess attenuation is near 2 dB, but an extra attenuation of up to 6 dB can be achieved. When comparing the performance of two thin barriers of the same height in the same construction site, one of them having a straight edge cantilever and the other one, a slanted flat-tip jagged cantilever, the last one achieved an additional attenuation of up to 5 dBA [28]. Last but not least, there are many designs of cappings that includes ANC technologies.

3.3 Green barriers

A green barrier designed to have an acoustic function should not be confused with an esthetic one. In fact, guidelines for greening acoustic barriers can be found, for example [29].

A study carried out in Virginia (US) concluded that “*there was minimal noise attenuation that could be attributed to the coniferous trees at the 15 study sites examined. Attenuation was not correlated with tree stand age, height, species, or density for these sites.*” [30]

Shrubs and trees should meet certain characteristics to take part in a noise barrier. The depth of the green curtain may be at least 15–40 m. Even if its best performance is between 250 and 1000 Hz, an attenuation greater than 3 dB in L_{Aeq} should not be expected. The best attenuation performance of a green barrier occurs at a wavelength twice the size of the leaves of the tree species [20].

The expression for estimating the attenuation of a dense green barrier, proposed by Kurze, Beranek and Hoover, as presented in Ref. [31]:

$$\Delta L [dB] = \frac{d [m]}{100} f^{\frac{1}{3}} \quad (8)$$

Even if direct relations between the IL and the length, depth and diameter of the branches of urban green curtains have been reported and drawn [32], analytic expressions for predictive purposes are not easy to develop.

It is usually assumed that the attenuation of green barriers is almost negligible for frequencies below 400 Hz and that they may be useful only for frequencies above 1000 Hz, provided that the curtain is dense and its thickness is several tens of meters in depth. The improvement in the attenuation in low-frequencies is mostly related to fallen leaves and branches, which increases the surface porosity and thus, the ground absorption. Martens’ work shows the best performance is reached when the leaf dimension is similar to half of the wavelength to absorb [20].

In a study analyzed in Ref. [31], the acoustic attenuation of two green barriers of cedar trees 4–4.5 m in height is compared. In the first case, the trees were aligned by rows and columns, in an area of 30 m × 5 m, very close to one another, with branches overlapping; in the other case, The trees were planted in a diagonal pattern, on the vertices of equilateral triangles of 1.20 m side (quincunx pattern)., occupying an area of 25 × 9.20 m. The results are shown in **Table 5**.

The absorption coefficient of leaves and plants seems to be low. Low absorption coefficients were found up to 1600 Hz, most of them no greater than 0.30. The best performance was that of Winter *Primula vulgaris*, with values between 0.6 and 0.7 for frequencies of 500–1600 Hz; and the worst, *Hedera Helix*’s, with all values below 0.20.

	Rows and columns	Diagonal
630 Hz	1.2	0.4
2000 Hz	2.6	5.2
5000 Hz	5.5	—
10,000 Hz	8.3	11.3

Table 5. Attenuation of a green barrier of cedar trees in dB/m of curtain depthness in two different arrangements (from Ref. [31]).

The study states that “the leaf area density and dominant angle of leaf orientation are two key morphological characteristics that can be used to predict accurately the effective flow resistivity and tortuosity of plants” [33]. Two other studies obtained similar results [34, 35]. The main conclusion of Asdrubali et al. [34] was that “the main absorber is the substrate soil (...). The presence of the plants becomes useful only when a large number of them is installed on the sample, otherwise is even pejorative within some frequency ranges.” Just the opposite, Azkorra et al. [36] obtained a weighted sound absorption coefficient of 0.40, but the best absorption coefficients were at frequencies of 125 and 4000 Hz, and the worst ones, were at 500 and 1000 Hz.

3.4 Sonic crystal (acoustic open barriers)

Sonic crystals (SC) are periodic structures that have been studied in recent decades to learn about their possibilities of behaving as “acoustic open barriers”. They have been also been studied for using them for sound diffusion [37].

The idea of an open barrier seems incompatible with the tightness and continuity of the surface of a “conventional” barrier. A SC is a periodic structure that can be triangular, squared, rectangular, or hexagonal; the best geometry is triangular [16]. The essential point is that the structure is the same regardless of the orientation of the material. Depending on the number of dimensions in which the pattern is repeated, the SC will be one-dimensional, two-dimensional, or three-dimensional. The most useful structure for acoustic barriers is two-dimensional with Cermet’s topology (i.e., there is no contact between one scatterer to the other, each scatterer is totally surrounded by the external fluid—the air in this case) [38]. Thus, the key is that the operation principle is different in nature—the SC does not attenuate noise by diffraction, but by Bragg interference, widely used in optics—when a wave reaches a crystal structure surrounded by a fluid, the energy of some frequencies cannot be transmitted. These frequencies are the so-called “Bragg frequencies.” This occurs due to a destructive interference caused by a multiple scattering process [16, 37–39]. If a is the distance between two scatterers, the main controlled frequency will be $f = c/2a$ (c is the sound velocity and a is the so-called *constant of the lattice*). Due to the destructive interference caused by the SC structure, all the acoustic energy at that frequency is reflected. This frequency itself is a *bandgap*; the width of the bandgaps is linked to the *filling factor*, which represents the fraction of the lattice area that is occupied by scatterers. The greater the filling factor—without losing the crystal structure—the best IL is achieved; but if the filling factor is close to 1, the SC will become a continuous barrier [38]. It is worth mentioning that the height of the barrier is not a critical factor in the design [16].

The main advantages of acoustic open barriers are that they are lighter, easier to install and they do not need to have a significant additional height above the source. Research on this technology in the last years has allowed the development of new metamaterials, for example, a scatterer consisting of an absorbent split ring resonator, which has the structure of a SC with a cavity to act as a Helmholtz resonator and an absorbing material to reduce the acoustic energy at high frequencies [38].

4. Passive control at the receivers

It refers to actions aimed at improving acoustic insulation in recipients' homes, through constructive solutions, materials with better acoustic performance, windows sealers, special openings, or with double glass. When none of these options seems to be a solution, the use of personal protection equipment (PPE) is the last option. PPE are not only used by workers: many people who are very sensitive to noise have to wear these devices to sleep, or at least to fall asleep.

Even though, there is another way to improve sound quality for the recipients: it consists of masking the undesirable signal. Even if it is closer to an active method for noise control—it consists of adding acoustic energy to the system—it may not be considered as an ANC technique. Masking is a natural human auditive function: some signals can lift the hearing threshold levels at certain frequencies. With basis on this concept, the common idea of masking solutions attempts to mask high frequencies for making speech incomprehensible to adjacent rooms, for example, between a waiting room and a doctor's office, or between a meeting room and a reception area. In all these cases, the most common technique is music masking. Other options and applications are available as well, for example, the use of white noise or a water fountain sound for enhancing acoustic quality to the receivers [40], which has been studied for a long time to make soundscapes healthier [41].

5. Active noise control (ANC)

ANC refers to a technique that aims to reduce the SPL through the emission of sound signals in the counter phase with those that occur in the system to control. Then, destructive interference is generated between both signals. This method involves adding acoustic energy to a system that already has an excess of acoustic energy; thus, it should be applied very carefully. On the other hand, active silencers are more accurate and versatile than passive ones. ANC can be used in the source, during sound propagation or at the receiver. Best results should be expected when the signal is periodic, low frequency, and narrow band.

In a similar way to ANC techniques, there are active vibration control techniques. They act with analogous principles, but in this case, they introduce oscillations to counteract the original vibrations.

5.1 Main components of an active noise control system

An ANC system consists of the following components:

- A primary acoustic field, which is the acoustic field to be controlled.

- Detection sensors or transducers, which allow characterizing the signal to be controlled and provide the information to the system controller.
- Error sensors, which take information after the cancelation (that is, the sum of the primary signal plus the secondary signal -or control signal-), to inform the controller to perform the necessary corrections so that the result is as close as possible to zero.
- Actuators, which are electroacoustic devices (commonly, an amplifier and a loudspeaker) that receive the controller's instructions to emit a certain cancelation signal to modify the primary acoustic field ("anti-noise" or "counterwave", a sound with the same amplitude and frequency of the signal to control, but in opposite phase).
- A controller, on which the success of the system depends on. It is the electronic system that processes the signals from the error detection and control sensors, generates the signal to be emitted, and defines the delay with which it must be emitted; lastly, it sends the order to the actuators to emit it. The delay between the primary and secondary signal must be adjusted taking into account the primary detection sensors and the error sensors. The controller optimizes the attenuation of the error signal provided by an adaptive algorithm that varies the filter operating coefficients in real-time.

The system works as follows:

- A detection sensor (e.g., a microphone) receives the signal to be controlled and sends this information to the controller.
- The controller generates an equal wave (secondary field) but in the opposite phase and sends it to the actuator with a certain delay, which is the time that the controller calculates for the wave to reach the designated point.
- The actuator emits the signal indicated by the controller.
- Another sensor (an error sensor or error microphone) is located after the actuator receives the two added signals, primary and secondary, whose result should be as close as possible to zero, and sends it to the controller.
- As in practice, the result is not usually exactly null, the controller will make an adjustment to minimize the error.

5.2 Applicability of active noise control systems

The main rules of thumb for applying an ANC system are the following:

- The system should be as robust and powerful as possible.
- The minimum sampling frequency required by the controller must satisfy the Nyquist theorem: $f_{min,sampling} \geq 2f_{Max}$ of the frequencies to control. In other words, the minimum sampling frequency necessary to describe a signal of 500 Hz

is at least 2×500 , that is, 1000 samples per second. Hence, the lower the frequency of the signal to be treated, the less demanding this aspect becomes. Please, note that the Nyquist theorem is a necessary condition but not a sufficient one to achieve a good description of the signal through sampling. At first, this was a major limitation for the use of the ANC systems. Advances in communications technologies have broken down this barrier.

- The abovementioned condition implies that the processing time by the controller should be less than the time between two samples. The maximum available time between the income signal sent by the reference sensor and the emission of the cancelation signal by the actuator is usually a few milliseconds. For example, for 500 Hz, the minimum sampling rate is 1000 samples per second; thus, the processing time should be less than $1/1000 = 1$ ms.
- The causality condition establishes the minimum length that the noise-canceling system must be above a certain frequency, to guarantee that the acoustic delay δA is being considered. To ensure that the adaptive filter has a causal response, it is necessary that $\delta A > \delta E$, δE is the total electrical delay (sum of the delays of the entire analog-digital system, including the controller, the digital filter, the loudspeaker, the processing time and so on. δA is the time taken by the flow to pass through the input microphone.
- The closer the two sources are (primary and secondary), the greater the reduction in the total sound power of the ensemble.
- The greatest efficiency of the solution occurs when the separation between sources is not greater than 0.1λ : reductions of 10 dB or more can be achieved.
- If the separation between sources becomes greater than 0.3λ , the attenuation will be negative, that is, the net acoustic power of the ensemble will increase.
- From the previous conditions, it turns out that ANC is more favorable the greater the wavelength of the signal to be controlled. These systems are generally applied for frequencies up to 500 Hz ($\lambda_{500 \text{ Hz}} \approx 0.68$ m).
- If the cancelation signal is emitted by more than one source, the greater the number of secondary sources, the better the result.
- To control a signal with significant amounts of energy in low and high frequencies, mixed solutions (active and passive) should be considered.

5.3 Control strategies in active noise control systems

There are two basic control strategies in ANC systems: anticipatory or feedforward control and feedback control.

The applicability of *feedforward control* relates to cases whether the propagation time between the reference microphone (the primary sensor) and the cancelation loudspeaker (the secondary source) is sufficient—in electrical terms—so that the canceling signal could be reintroduced downstream when the primary noise signal “passes” the loudspeaker. This is why active control was originally reserved for low-

frequency sounds since at lower frequencies there was more time (or distance traveled) to insert the secondary signal. The objective of the system is to minimize the error signal so that the residual acoustic noise error (i.e., the sum of the original and input signals) results as low as possible.

The *feedback system* is simpler than the feedforward one, but it can only be applied if the signal to be controlled is well known and very stable, that is, with very few variations. Thus, the need to know the signal to be controlled at all times is avoided since the system assumes it is a fixed and known input.

A single microphone is used as an error microphone, which registers the sum of the signal to be canceled plus the cancelation signal. The information is sent to a simpler control system, which sends the signal to be emitted to the actuator aiming to minimize the error between the current signal and the predefined one.

A combination of both systems is also possible to be used (“hybrid control”). *Hybrid control* (FF/FB) refers to a two-degree-of-freedom controller, which enables robust performance over a larger range of frequencies. The design of each controller depends on the design of the other, for example, DEUS control structure output (two inputs, one output). In 2020, another structure for ANC systems was proposed [42]; it modifies the path for measuring the error.

Adaptive controllers may be mentioned as well. They allow good performance to be achieved even when the information of the signal to be processed is incomplete. When working under stationary conditions, an adaptive controller quickly converges to Wiener’s optimal solution; when working in nonstationary conditions, the algorithm allows tracking time variations in the input data, as long as these variations are slow enough to track. Controllers can apply many possible algorithms, including the classic “least mean squares.”

5.4 Some applications of active control

Possibly the most successful case in using ANC is that of active hearing protectors, which generate a counterwave to protect workers exposed to high SPL. ANC-ear protectors were one of the first applications of massive use of ANC; they met great commercial interest. Its use for the protection of workers is not the only application: not considering its dangers, it may be said that there are also motorcycle helmets with ANC, due to the occupational exposure of those who work on motorcycles (deliverymen, police officers [43]). Other nonpassive protectors are those that allow selective filtering of some frequency bands, such as those which are especially of interest to musicians; and those that allow masking the source by emitting a different signal (e.g., white noise, or even turning a radio on).

The applications of active control in the propagation medium are diverse and some of them are novel. A modern system for indoor urban noise control is through ANC. A 10 dB reduction in traffic and railway noise was achieved on frequencies from 100 Hz to 1000 Hz for canceling the incoming signals in a real window of $1\text{ m} \times 1\text{ m}$ [44]. There are ANC systems for controlling SPL in the interior of a vehicle [45], a “noise-canceling office chair” [46] and a “capsule” for home devices, to control both noise and vibrations [47].

An interesting application of ANC is that proposed for a real case of thermoacoustic instabilities in large combustion engines. Shortly explained, thermoacoustic instabilities appear when working with machinery and equipment on such a scale that the main phenomena, such as mixing or ignition, cannot be considered punctual neither instantaneous nor homogeneous throughout the combustion

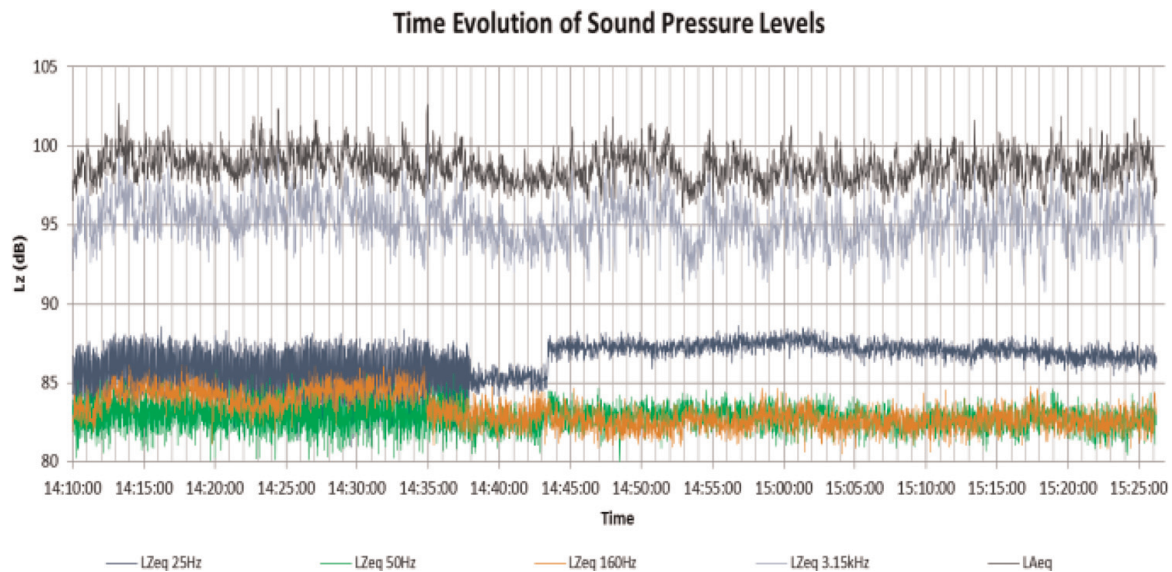

Figure 7. Installation of thermoacoustic instability in the 25 Hz third-band octave from a large engine (from Ref. [49]).

chamber. Thus, the system can frequently enter into resonance if there is coupling with some geometric dimension.

When preparing this entry into resonance, a process of “loss of chaos” is observed [48], which reaches the condition of thermoacoustic instability from which, after some time that is not fixed or preestablished, the system recovers and returns to normal.

In this case study, a detailed analysis of the problem showed that fluctuations in the pressure of the fuel inlet line were occurring, leading to the occurrence of the abovementioned instabilities. One of the three ways in which these were manifested was by the loss of chaos in sound emissions, as described in Ref. [48]. The phenomenon appears especially in the 25 Hz third-octave band (blue line in **Figure 7**). The transition lasts several minutes, and it can be seen that the loss of chaos is the preamble for the emission in that band to present an abrupt increase of SPL about 5 min later. The suggested solution was a typical feedforward ANC system since there was a reaction gap of several minutes.

6. Final remarks

An overview of techniques for noise control has been presented. The most common passive solutions and their applications have been described; generalities and actuality of ANC have been reported as well.

This chapter will fulfill its objective if it serves only as a guide for selecting options for solving practical situations, but of course, a more in-depth approach is needed for their acoustic design.

Conflict of interest

The author declares no conflict of interest.

IntechOpen

IntechOpen

Author details

Alice Elizabeth González

IMFIA, Faculty of Engineering, Universidad de la República UdelaR (University of the Republic), Montevideo, Uruguay

*Address all correspondence to: elizabet@fing.edu.uy

IntechOpen

© 2022 The Author(s). Licensee IntechOpen. This chapter is distributed under the terms of the Creative Commons Attribution License (<http://creativecommons.org/licenses/by/3.0>), which permits unrestricted use, distribution, and reproduction in any medium, provided the original work is properly cited. 

References

- [1] ASHRAE. Generator Noise Control—An Overview. USA: ASHRAE Technical Committee 2.6 on Sound & Vibration; nd
- [2] Strahle WC. Combustion noise. USA: Journal of Progress in Energy and Combustion Science. 1978;4(3-A): 157-176
- [3] Harris C. Manual de Medidas Acústicas y Control de Ruido. Mexico: McGraw-Hill; 1995. p. 1328
- [4] Briggs J, Sacks M, Kraemer S. Heat Recovery Steam Generator Noise Attenuation. nd. 1995. p. 13
- [5] Pettersson H. Environmental Noise Control in the Pulp and Paper Industry. Sevilla, España: Tecniacústica 2002; 2002. p. 6
- [6] Gerges SNY. Ruido, Fundamentos e Controle. Brasil: Biblioteca Universitária, Universidade Federal de Santa Catarina; 1992. p. 600
- [7] Pérez Barber D. Proyecto Fin de Carrera: Modelado acústico de silenciadores. España: Escuela Superior de Ingenieros de Sevilla, U. de Sevilla; 1992
- [8] Giraldo Arango JM. Control del ruido en la construcción de obras públicas. In: Proceedings of International Seminar on Environmental Noise; March 2008; Medellín, Colombia. 2008 ISBN: 978-958-44-3029-8
- [9] González AE. Noise sources in the city: Characterization and management trends. In: Siano D, editor. Noise Control, Reduction and Cancellation Solutions in Engineering. London, USA: IntechOpen; 2012. DOI: 10.5772/25879
- [10] Teti L, de León G, Del Pizzo A, Moro A, Bianco F, Fredianelli L, et al. Modelling the acoustic performance of newly laid low-noise pavements. Construction and Building Materials. 2020;247:118509. p. 11
- [11] Licitra G, Moro A, Teti L, Del Pizzo A, Bianco F. Modelling of acoustic ageing of rubberized pavements. Applied Acoustics. 2019;146:237-245
- [12] Gruber M. Airfoil noise reduction by edge treatments [PhD thesis]. University of Southampton, Institute of Sound and Vibration Research, Faculty of Engineering and the Environment; 2012. p. 229
- [13] Gianoli P, Cataldo J, González AE. Impacto acústico de la interacción entre el viento y las edificaciones. In: Revista do IPT do III Congresso Latino Americano de Engenharia do Vento; Sao Pablo, Brasil. 2018. p. 6
- [14] Lisboa MR, Cataldo Ottieri J, González AE. Noise annoyance due to wind flow interaction with a building's facade. Open Journal of Acoustics. 2015; 5:1-10. DOI: 10.4236/oja.2015.51001
- [15] Government of the Hong Kong, Environmental Protection Department, Highways Department. Guidelines on Design of Noise Barriers. 2nd Issue. January 2003
- [16] Peiró-Torres MP, Bravo JM, Redondo J, Ferri M, Sánchez-Pérez JV. Pantallas acústicas abiertas. In: Cuadernos tecnológicos de la PTC N°6/2015. Madrid, España: Plataforma Tecnológica Española de la Carretera (PTC); 2015
- [17] European Commission. Directive 2002/49/EC and its modifications
- [18] Yagüe DC, María J. Caracterización morfológica y geométrica de curvas tipo para diseño de pantallas acústicas

tubulares y su aplicación al campo de la protección ambiental en Ingeniería Civil [Tesis Doctoral]. Madrid, España: Universidad Politécnica de Madrid; 2001

[19] Yang T, Hu L, Xiong X, Petru M, Noman M, Mishra R, et al. Sound absorption properties of natural fibers: A review. *Sustainability*. 2020;**12**:8477. DOI: 10.3390/su12208477

[20] Kotzen B, English C. *Environmental Noise Barriers: A Guide to their Acoustic and Visual Design*. 2nd ed. Canadá and USA: Simoultaneously published; 2009. ISBN 10: 0-203-93138-6

[21] Kamisiński T, Kinasz R, Szeląg A, Rubacha J, Pilch A, Flach A, et al. The comprehensive research of the road acoustic screen with absorbing and diffusing surface. *Archives of Acoustics*. 2015;**40**(1):137-144

[22] Government of the Hong Kong SAR, Highways Department. Practice Notes No. BSTR/PN/003—Revision E. Noise Barriers with Transparent Panels. Bridges and Structures Division, October 2020

[23] Kolarević M, Grković V, Vukićević M, Bjelić M. Configuration of modular noise barriers. In: 4th International Conference on Noise and Vibration; Croacia. 2012

[24] Morgan SM, Kay DH, Bodapati SN. Study of noise barrier life-cycle costing. *Journal of Transportation Engineering*. 2001;**127**(3):230-236

[25] Guarnaccia C, Quartieri J, Mastorakis NE. Comparison of acoustic barriers noise reductions evaluated by different calculation methods. In: *Latest Trends on Systems—Volume II*. 2001. pp. 443-449. ISBN: 978-1-61804-244-6

[26] Pita Olalla E. Las pantallas antirruido y sus prestaciones. *Revista de Obras Públicas*. 1995;**3339**:77-88

[27] Ross JC, Arnoldy M, Evans J. New Hampshire department of transportation statewide noise barrier study. *Transportation Research Record*. 2018; **2672**(24):144-153. DOI: 10.1177/0361198118797188

[28] Zhaomeng W, Meng LK, Priyadarshinee P, Pueh LH. Applications of noise barriers with a slanted flat-tip jagged cantilever for noise attenuation on a construction site. *Journal of Vibration and Control*. 2018;**24**(22): 5225-5232. DOI: 10.1177/1077546317747779

[29] Government of the Hong Kong Special Administrative Region, Greening and Landscape Office, Greening, Landscape and Tree Management Section. *Guidelines on Greening of Noise Barriers*. 2012. p. 20

[30] Lee SE, Velasquez S, Flintsch G, Peterson J. Road noise attenuation study: Traffic noise, trees, and quiet pavement: A report in response to item 442 c. of Chapter 847 of the Acts of Assembly of 2007. The Virginia Transportation Research Council; 2008

[31] Ruza Tarrío Felipe. *La vegetación en la lucha contra el ruido*. 2008. p. 10

[32] Van Renterghem T. Guidelines for optimizing road traffic noise shielding by non-deep tree belts. *Ecological Engineering*. 2014;**69**:276-286 277. DOI: 10.1016/j.ecoleng.2014.04.029

[33] Horoshenkov KV, Khan A, Benkreira H. Acoustic properties of low growing plants. *JASA*. 2013;**133**:2554. DOI: 10.1121/1.4798671

[34] Asdrubali F, D'Alessandro F, Mencarelli N, Horoshenkov KV. Sound absorption properties of tropical plants for indoor applications. In: *The 21st*

International Congress on Sound and Vibration; July 2014; Beijing/China. 2014

[35] Rizzo La Malfa A, Velis A, Posse C, Armas A, Miguel S, Figueira A, et al. Sistemas modulares verticales: Evaluación de la absorción acústica en laboratorio. *Revista Ecos*. 2020;**1**(1):48-57

[36] Azkorra Z, Pérez G, Coma J, Cabeza LF, Bures S, Álvaro JE, et al. Evaluation of green walls as a passive acoustic insulation system for buildings. *Applied Acoustics*. 2015;**89**:46-56

[37] Redondo J, Sánchez-Pérez JV, Barreiro J, Iluminada P. Sobre el rendimiento de difusores de sonido basados en cristales de sonido. In: 45° Congreso Español de Acústica, 8° Congreso Ibérico de Acústica, European Symposium on Smart Cities and Environmental Acoustics; Murcia, España. 2014. pp. 787-793

[38] David RS. Utilización del método de los elementos finitos para el diseño teórico de una pantalla acústica basada en cristales de sonido [Graduation thesis]. Escuela Técnica Superior de Ingenieros de Telecomunicación, Universidad Politécnica de Valencia; 2019

[39] Rubio C, Castiñeira-Ibáñez S, Sánchez-Pérez JV, Candelas P, Belmar F, Uris A. Chapter 6: Open acoustic barriers: A new attenuation mechanism. In: *Advances in Noise Analysis, Mitigation and Control*. Croatia: IntechOpen; 2015. pp. 141-159. DOI: 10.5772/64360

[40] Piana EA, Roozen NB. On the control of low-frequency audible noise from electrical substations: A case study. *Applied Science*. 2020;**10**(637):20. DOI: 10.3390/app10020637

[41] Kogan P. Acústica Ambiental y el Paradigma del Paisaje Sonoro: Investigación exploratoria en áreas verdes y otros espacios urbanos [Tesis Doctoral].

Córdoba, Argentina: Universidad Nacional de Córdoba; 2018 . p. 274

[42] Figwer J, Michalczyk MI. Notes on a new structure of active noise control systems. *Applied Sciences*. 2020;**10**:4705. 20 pp

[43] Rosa C, Peña S, Ricardo S. Control activo de ruido acústico en cascos de motociclismo. *Revista Iberoamericana de Automática e Informática Industrial*. 2007;**4**(3):73-85

[44] Lam B, Shi D, Gan W, Elliott SJ, Nishimura M. Active control of broadband sound through the open aperture of a full-sized domestic window. *Nature Research, Scientific Reports*. 2020;**10**:10021

[45] Lee S, Lee S, Back J, Shin T. A new method for active cancellation of engine order noise in a passenger car. *Applied Sciences*. 2018;**8**:1394

[46] Sujbert L, Szarvas A. Noise-canceling office chair with multiple reference microphones. *Applied Sciences*. 2018;**8**:1702. DOI: 10.3390/app8091702

[47] Mazur K, Wrona S, Pawelczyk M. Performance evaluation of active noise control for a real device casing. *Applied Sciences*. 2020;**10**:377

[48] Vineeth N, Gireehkumaran T, Sulochana K, Saravanan G, Sujith R. Loss of chaos in combustion noise as a precursor of impending combustion instability. *International Journal of Spray and Combustion Dynamics*. 2013;**5**(4):273-290

[49] González AE, Cataldo-Ottieri J, Gianoli-Kovar P, Montero-Croucciée J, Lisboa MR. Measuring sound pressure levels during thermoacoustic instabilities in large engines: Case study. *Journal of Modern Physics*. 2017;**8**:1685-1699. DOI: 10.4236/jmp.2017.810099