

# Uniqueness of SRB measures for transitive diffeomorphisms on surfaces

F. Rodriguez Hertz

M.A. Rodriguez Hertz

A. Tahzibi

R. Ures

# question

what happens when volume is not preserved?

# question

what happens when volume is not preserved?

SRB measures are the most natural measures to study

# SRB measures

$\mu$  an  $f$ -invariant measure is SRB if

# SRB measures

$\mu$  an  $f$ -invariant measure is SRB if

▶  $\lambda^+(x) > 0$   $\mu$ -a.e.  $x$  in  $M$

# SRB measures

$\mu$  an  $f$ -invariant measure is SRB if

- ▶  $\lambda^+(x) > 0$   $\mu$ -a.e.  $x$  in  $M$
- ▶  $\mu^u \ll\ll \text{Leb}$

# Theorem [HHTU](2007)

$f : M^2 \rightarrow M^2$  is a  $C^{1+\alpha}$  diffeomorphism then

$$\#\{\text{SRB measures}\} \leq 1$$

# example

$\exists f : M^2 \rightarrow M^2$  transitive s.t.

$$\#\{\text{SRB measures}\} = 0$$

[HY1995]

$\mu$  ergodic SRB measure for  $f : M^2 \rightarrow M^2$

$\mu$  ergodic SRB measure for  $f : M^2 \rightarrow M^2$



$\mu$  hyperbolic measure

# ergodic homoclinic class

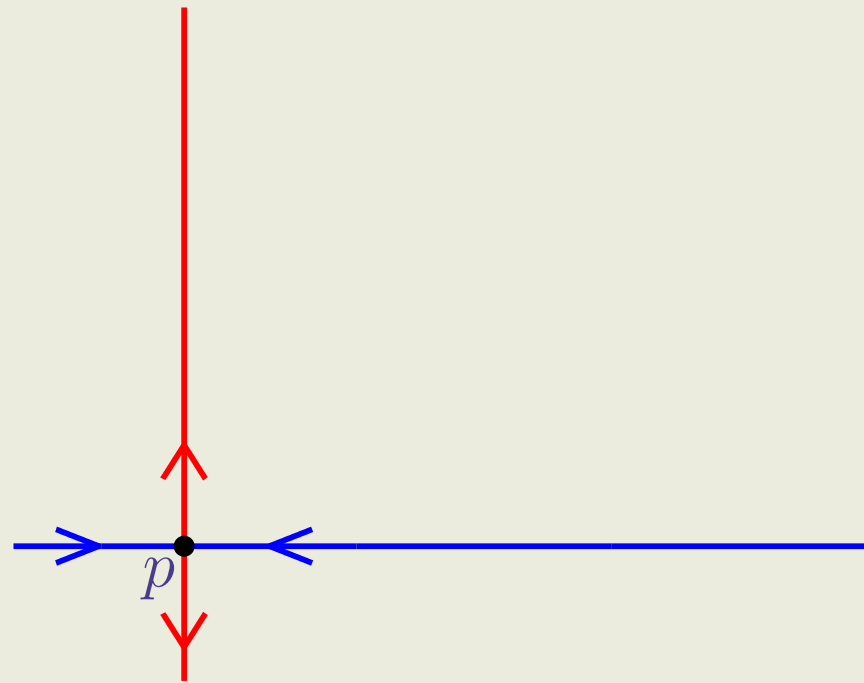

$$p \in \text{Per}_H(f)$$

# ergodic homoclinic class

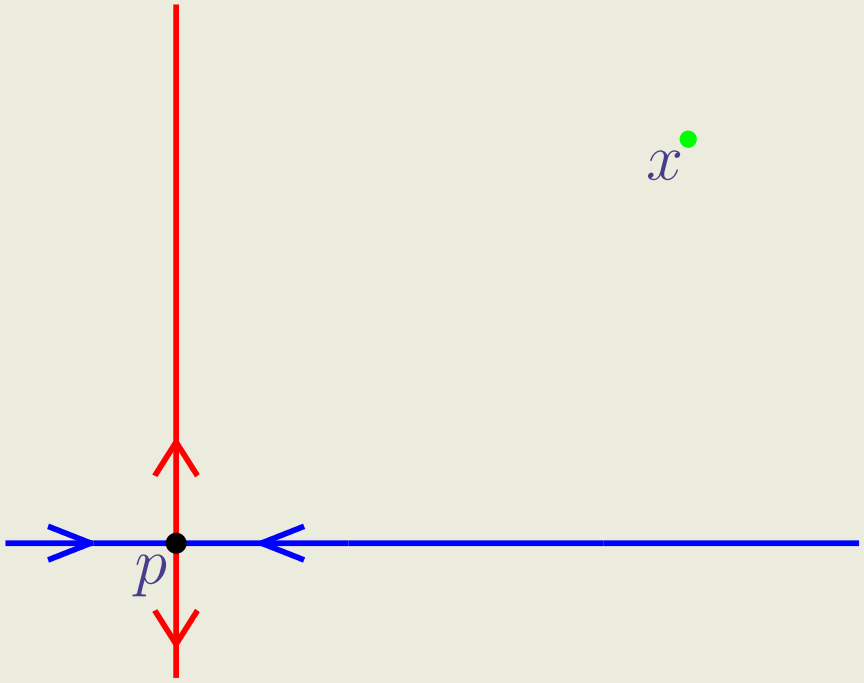

$$p \in \text{Per}_H(f)$$

▶  $x$  regular point

$x$

# ergodic homoclinic class

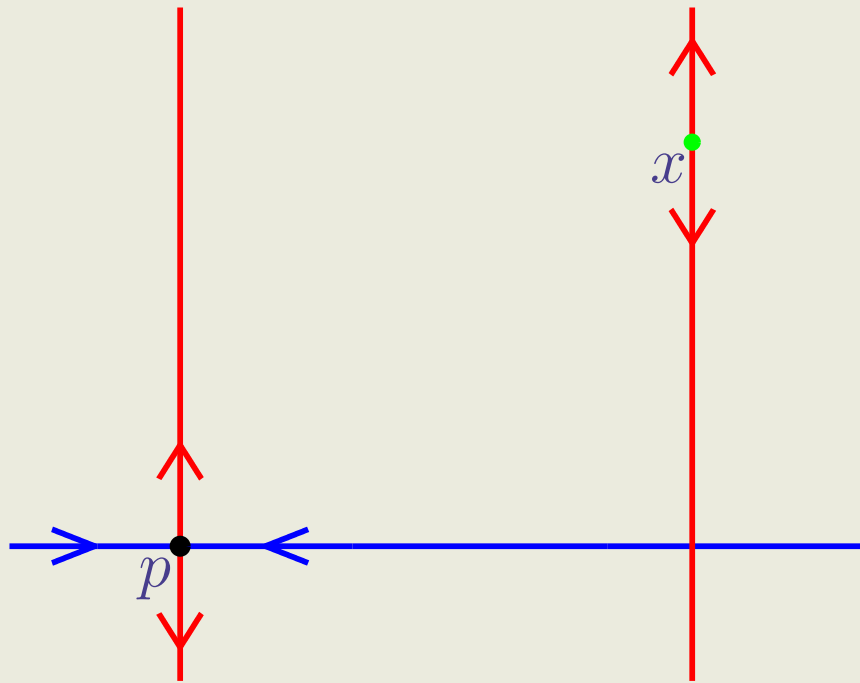

$p \in \text{Per}_H(f)$

- ▶  $x$  regular point
- ▶  $W^u(x) \cap W^s(o(p)) \neq \emptyset$

# ergodic homoclinic class

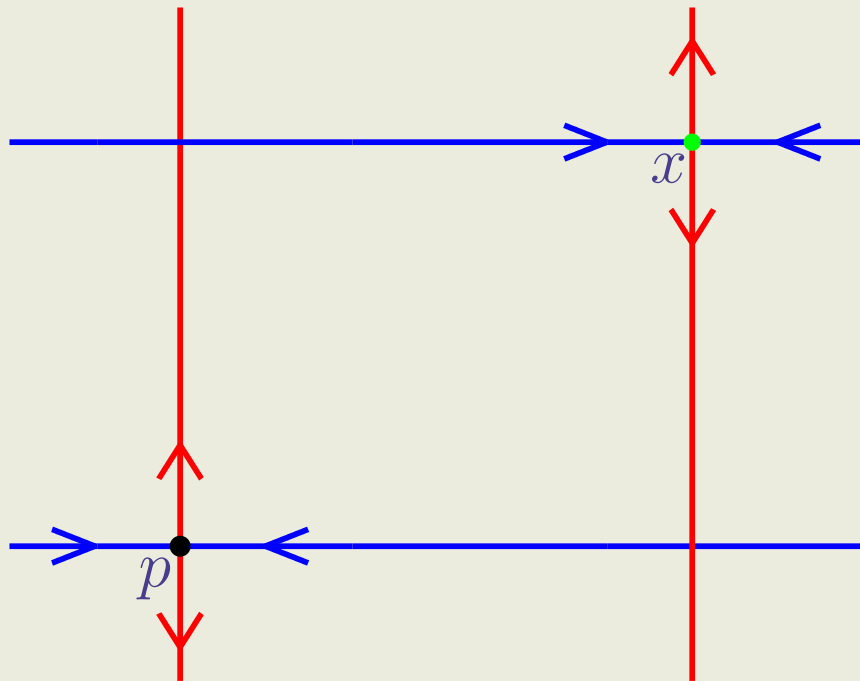

$p \in \text{Per}_H(f)$

- ▶  $x$  regular point
- ▶  $W^u(x) \cap W^s(o(p)) \neq \emptyset$
- ▶  $W^s(x) \cap W^u(o(p)) \neq \emptyset$

$x \in \Lambda(p)$

# proposition 1

$\mu$  ergodic SRB for  $f$ .

# proposition 1

$\mu$  ergodic SRB for  $f$ .

Then  $\exists p_\mu \in \text{Per}_H(f)$  such that

# proposition 1

$\mu$  ergodic SRB for  $f$ .

Then  $\exists p_\mu \in \text{Per}_H(f)$  such that

$$\mu(\Lambda(p_\mu)) = 1$$

$\mu$  SRB measure

$\mu$  SRB measure

$$M \stackrel{\circ}{=} \Lambda_1 \cup \Lambda_2 \cup \dots$$

Pesin-Leddrappier

$\mu$  SRB measure

$$M \stackrel{\circ}{=} \Lambda(p_1) \cup \Lambda(p_2) \cup \dots$$

where  $p_i \in \text{Per}_H(f)$

Pesin-Ledrappier-Katok

# sketch of the proof

$\mu, \nu$  ergodic SRB

$$\textcircled{1} \quad p_\mu \sim p_\nu \quad \Rightarrow \quad \Lambda(p_\mu) = \Lambda(p_\nu)$$

# sketch of the proof

$\mu, \nu$  ergodic SRB

①  $p_\mu \sim p_\nu \Rightarrow \Lambda(p_\mu) = \Lambda(p_\nu)$

②  $p_\mu \sim p_\nu$

# sketch of the proof

$\mu, \nu$  ergodic SRB

$$\textcircled{1} \quad p_\mu \sim p_\nu \quad \Rightarrow \quad \Lambda(p_\mu) = \Lambda(p_\nu)$$

$$\textcircled{2} \quad p_\mu \sim p_\nu$$

$$\textcircled{3} \quad \nu(\Lambda(p_\mu)) = 1 \quad \Rightarrow \quad \nu = \mu$$

# step 1

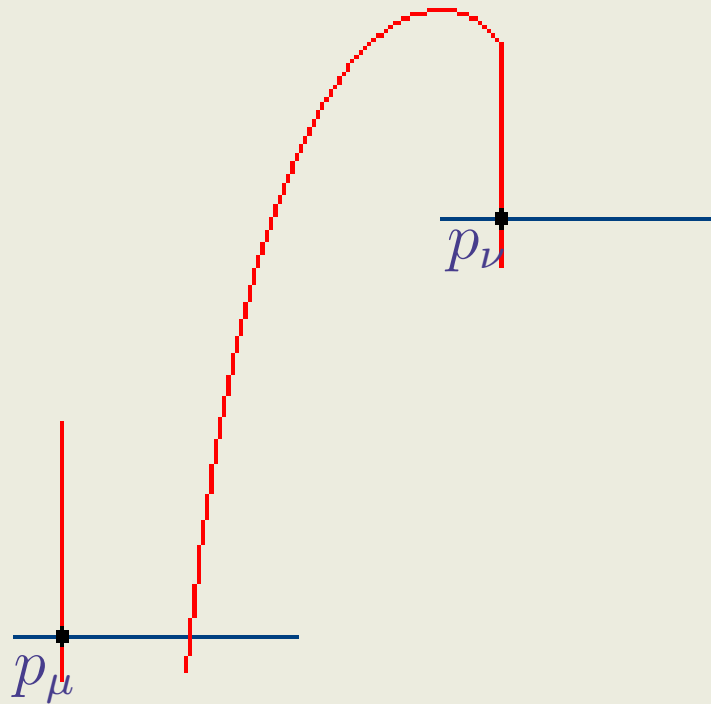

►  $W^u(p_\nu) \cap W^s(o(p_\mu))$

# step 1

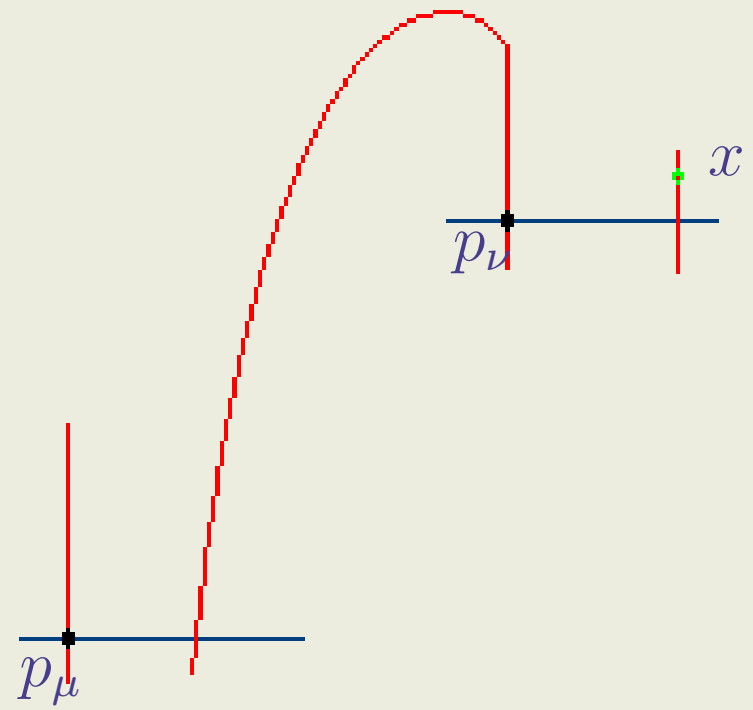

- ▶  $W^u(p_\nu) \cap W^s(o(p_\mu))$
- ▶  $x \in \Lambda(p_\nu)$

# step 1

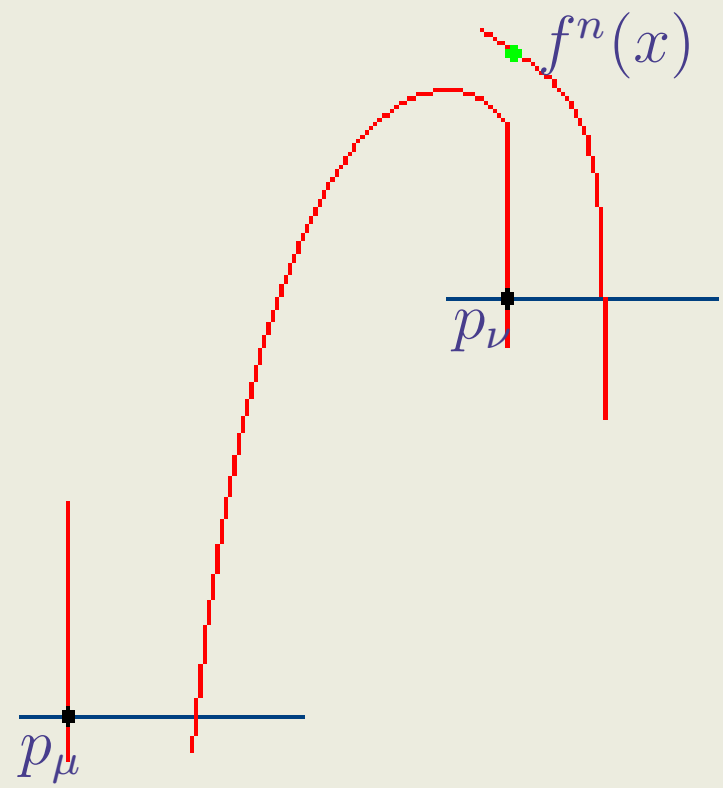

- ▶  $W^u(p_\nu) \cap W^s(o(p_\mu))$
- ▶  $x \in \Lambda(p_\nu)$
- ▶  $\lambda$ -lemma

# step 1

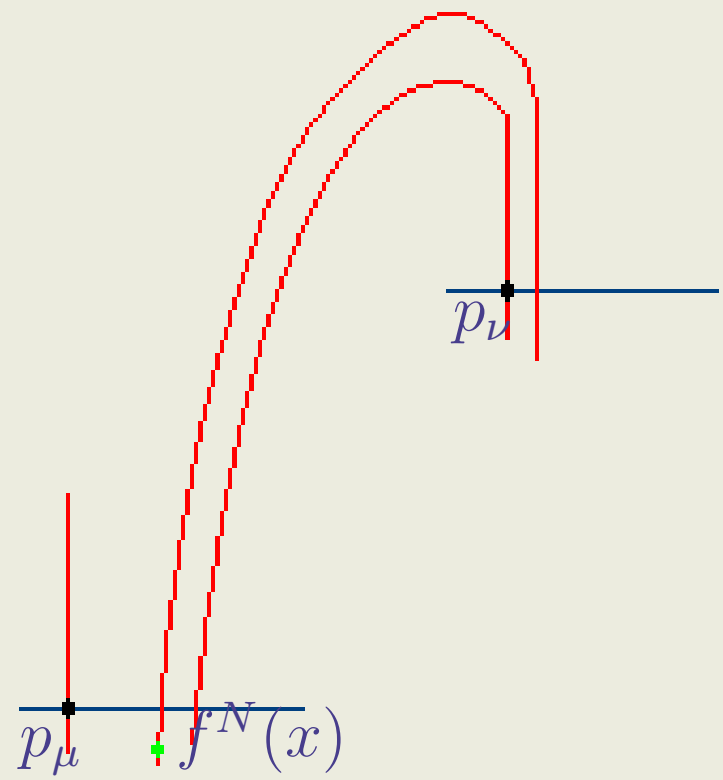

- ▶  $W^u(p_\nu) \pitchfork W^s(o(p_\mu))$
- ▶  $x \in \Lambda(p_\nu)$
- ▶  $\lambda$ -lemma
- ▶  $x \in \Lambda(p_\mu)$

# step 2

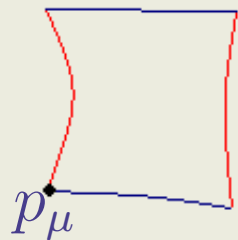
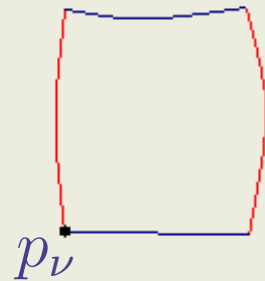

- ▶  $p_\mu, p_\nu$  have homoclinic intersections

# step 2

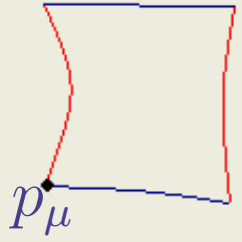
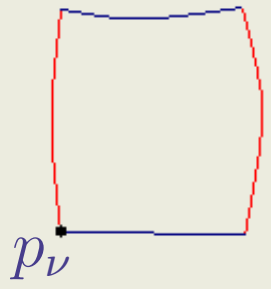

- ▶  $p_\mu, p_\nu$  have homoclinic intersections
- ▶  $R_\mu, R_\nu$   $su$ -rectangles

# step 2

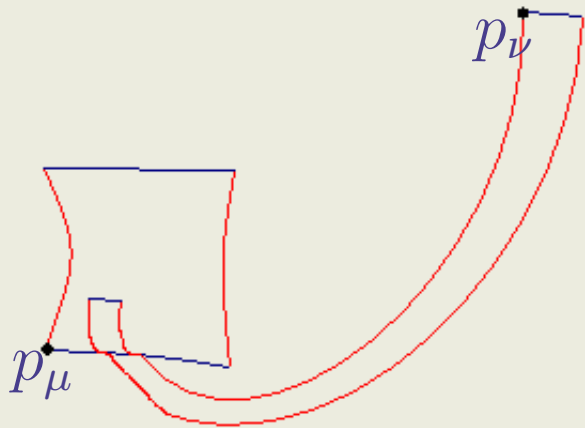

► transitivity

# step 2

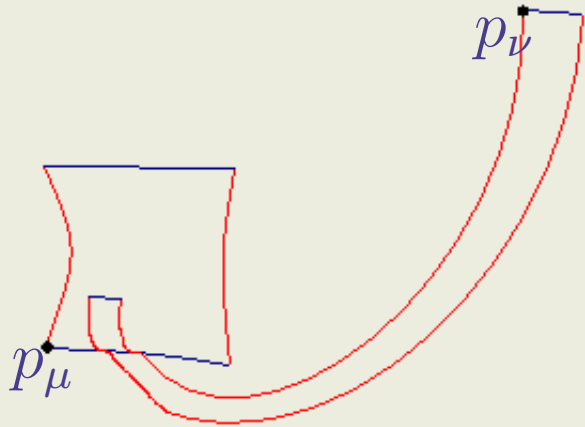

► transitivity

►  $W^u(p_\nu) \cap W^s(p_\nu) \neq \emptyset$

# step 2

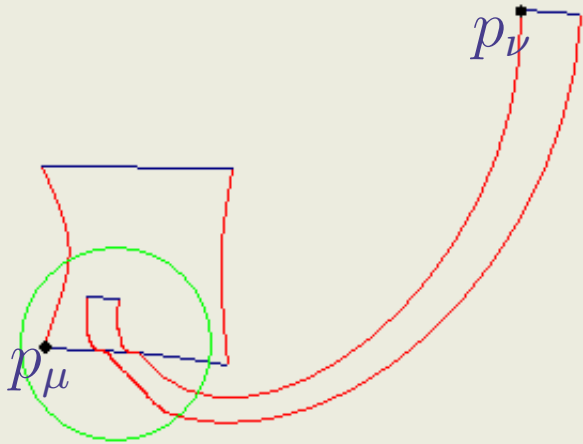

► transitivity

►  $W^u(p_\nu) \cap W^s(p_\nu) \neq \emptyset$

# step 2

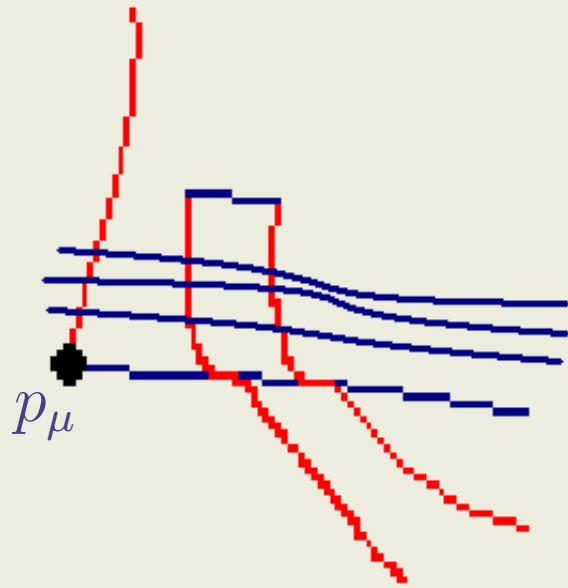

►  $m_p^u(\Lambda(p)) > 0$

# step 2

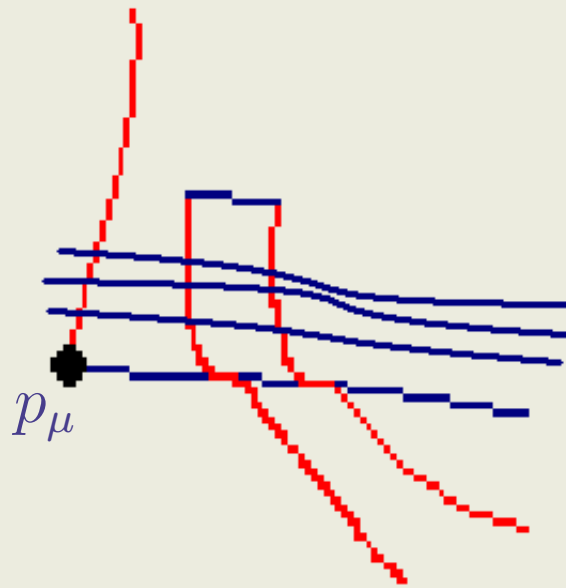

- ▶  $m_p^u(\Lambda(p)) > 0$
- ▶  $x \rightarrow W^s(x)$  is  $C^1$  in the Pesin block

# step 2

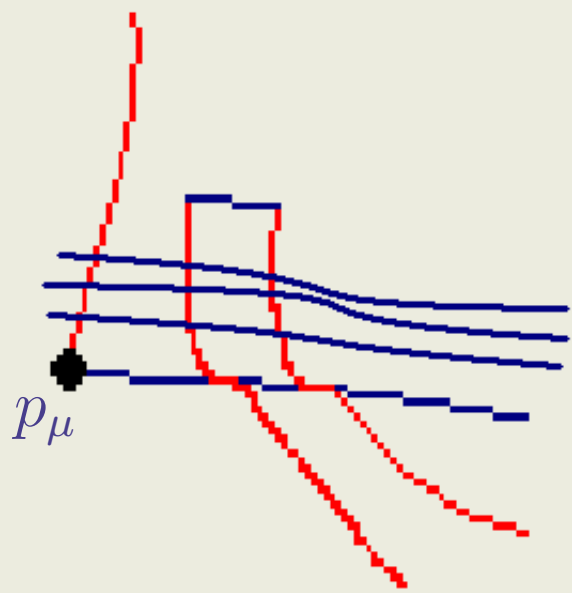

- ▶  $m_p^u(\Lambda(p)) > 0$
- ▶  $x \rightarrow W^s(x)$  is  $C^1$  in the Pesin block
- ▶  $W^u(p_\nu) \bar{\cap} W^s(p_\mu)$

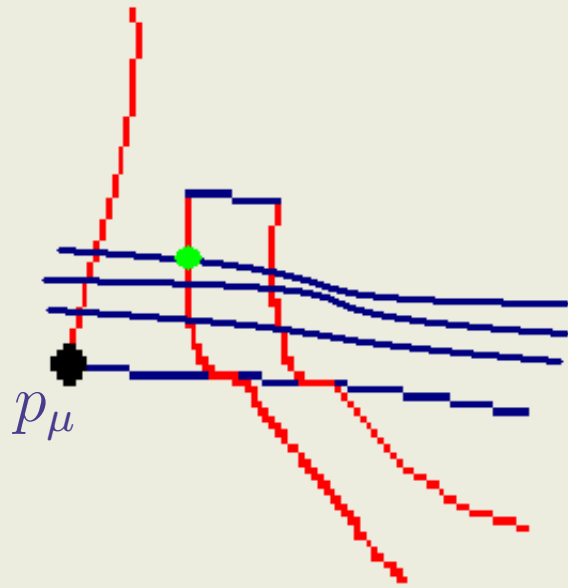

► Sard's theorem

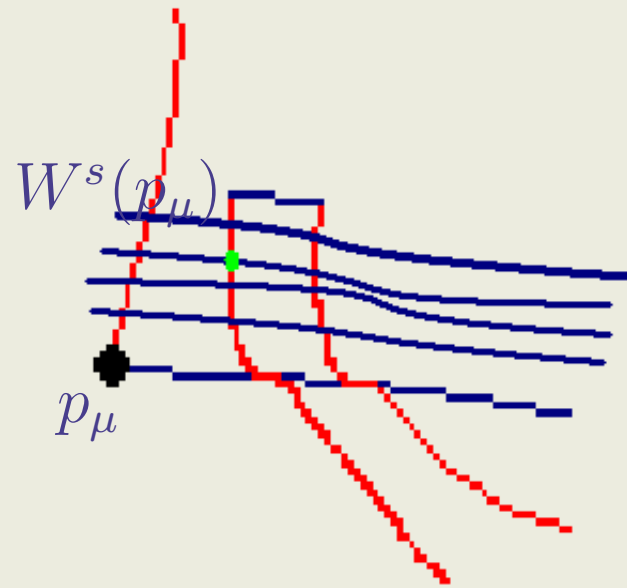

- ▶ Sard's theorem
- ▶  $W^s(p_\mu)$  approximates  $W^s(x)$

# step ③



$$\varphi^\pm(x) = \lim_{n \rightarrow \pm\infty} \frac{1}{n} \sum_{i=0}^{n-1} \varphi \circ f^i(x)$$

# step ③



$$\varphi^\pm(x) = \lim_{n \rightarrow \pm\infty} \frac{1}{n} \sum_{i=0}^{n-1} \varphi \circ f^i(x)$$

- ▶  $\varphi^+(\cdot)$  constant on  $W^s(x)$  for all  $\varphi \in C^0$

# step ③



$$B_\nu = \{x : \forall \varphi \in C^0 \quad \varphi^+(x) = \varphi^-(x) = \int \varphi d\nu\}$$

# step ③

- ▶  
$$B_\nu = \{x : \forall \varphi \in C^0 \quad \varphi^+(x) = \varphi^-(x) = \int \varphi d\nu\}$$
- ▶  $\nu(B_\nu) = 1$

# step ③



$$B_\nu = \left\{ x : \forall \varphi \in C^0 \quad \varphi^+(x) = \varphi^-(x) = \int \varphi d\nu \right\}$$

$$\nu(B_\nu) = 1$$



$$A_\nu \subset B_\nu : \quad x \in A_\nu \quad \Rightarrow \quad y \in B_\nu m_x^u - \mathbf{a.e.} y \in W^u(x)$$

# step ③



$$B_\nu = \{x : \forall \varphi \in C^0 \quad \varphi^+(x) = \varphi^-(x) = \int \varphi d\nu\}$$



$$\nu(B_\nu) = 1$$



$$A_\nu \subset B_\nu : \quad x \in A_\nu \quad \Rightarrow \quad y \in B_\nu m_x^u - \mathbf{a.e.} y \in W^u(x)$$

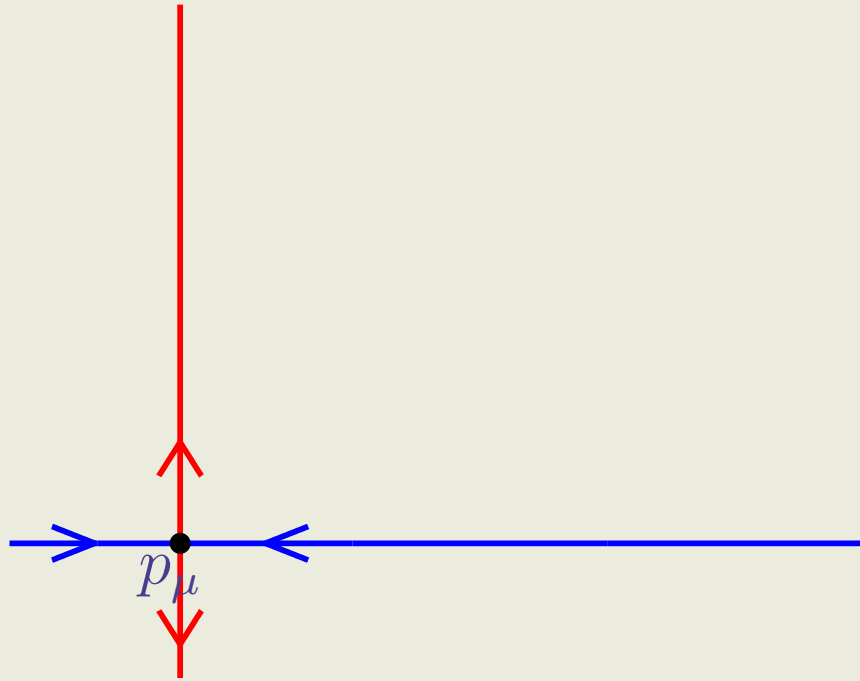

$$\nu(A_\nu) = 1$$

# step 3

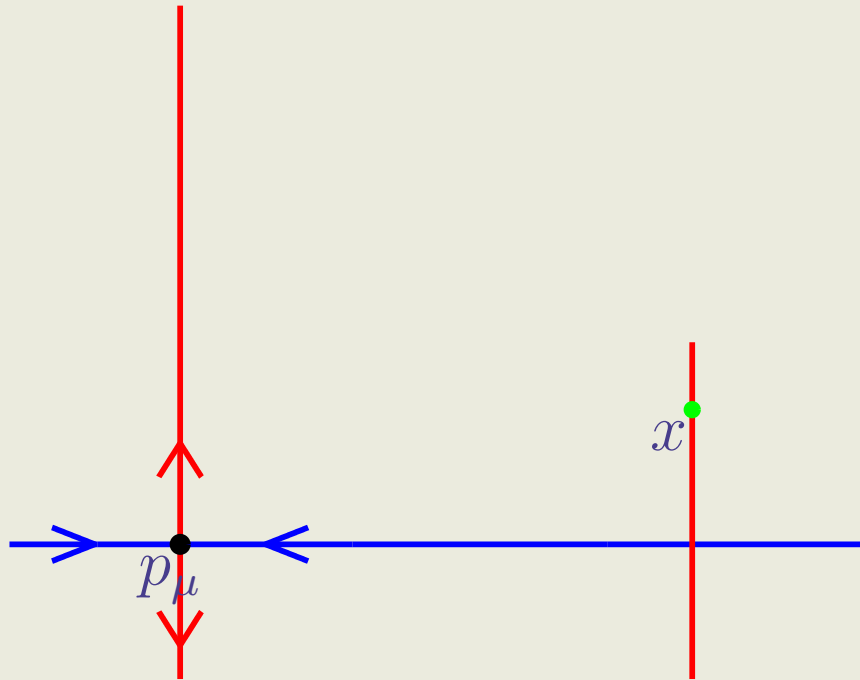

►  $\nu(\Lambda(p_\mu)) = 1$

# step 3



►  $\nu(\Lambda(p_\mu)) = 1$

►  $x \in A_\mu \cap \Lambda(p_\mu)$

# step 3

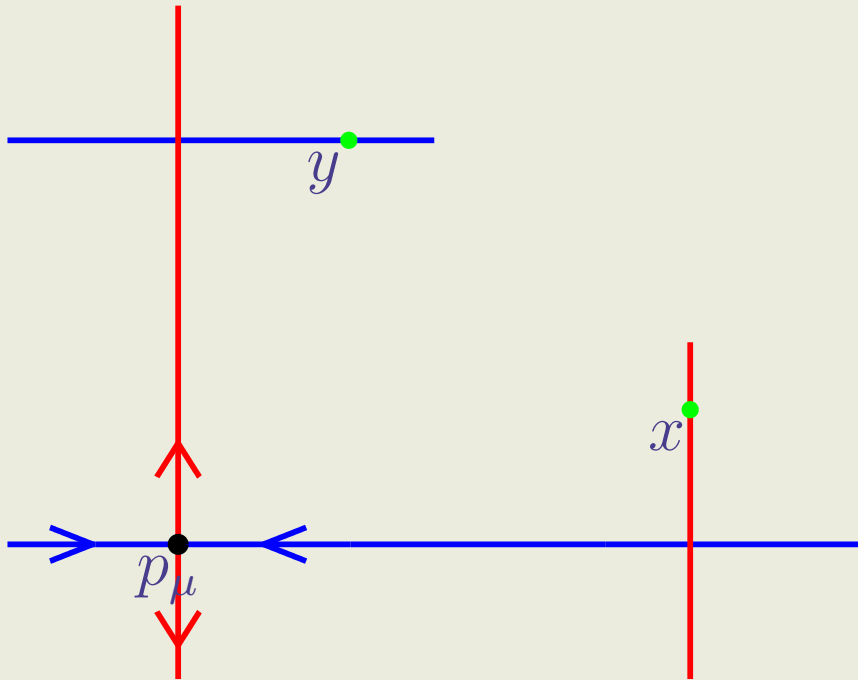

- ▶  $\nu(\Lambda(p_\mu)) = 1$
- ▶  $x \in A_\mu \cap \Lambda(p_\mu)$
- ▶  $y \in A_\nu \cap \Lambda(p_\mu) \cap \Lambda_\varepsilon$   
recurrent

# step 3

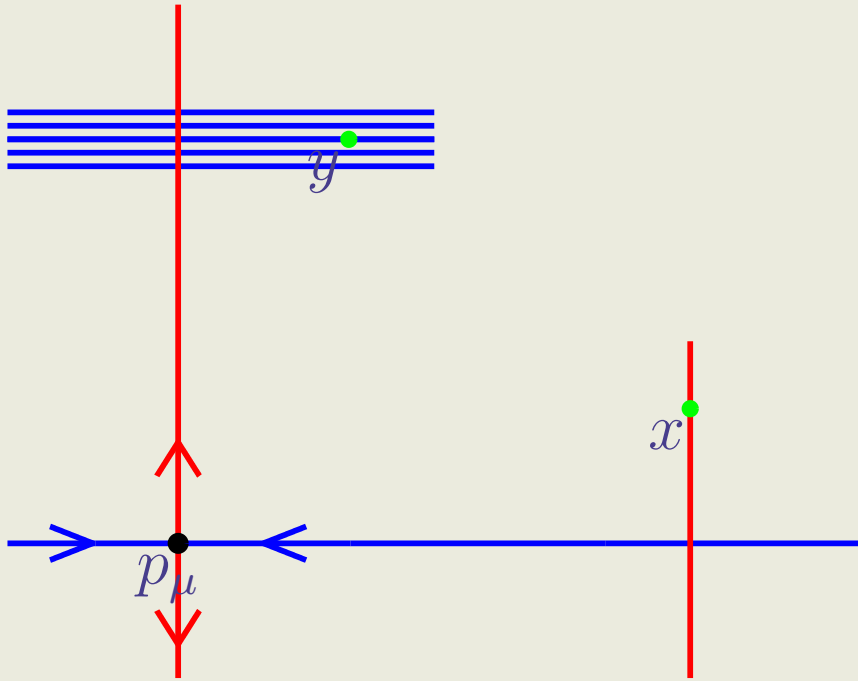

- ▶  $\nu(\Lambda(p_\mu)) = 1$
- ▶  $x \in A_\mu \cap \Lambda(p_\mu)$
- ▶  $y \in A_\nu \cap \Lambda(p_\mu) \cap \Lambda_\varepsilon$   
**recurrent**
- ▶  $y : \nu(B_\delta(x) \cap \Lambda_\varepsilon) > 0$

# step 3

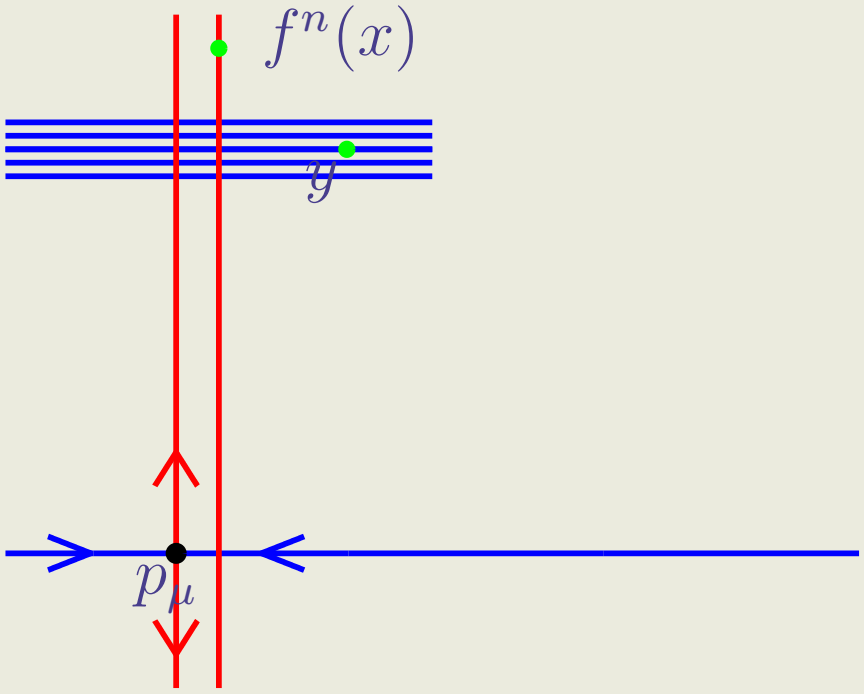

- ▶  $\nu(\Lambda(p_\mu)) = 1$
- ▶  $x \in A_\mu \cap \Lambda(p_\mu)$
- ▶  $y \in A_\nu \cap \Lambda(p_\mu) \cap \Lambda_\varepsilon$   
recurrent
- ▶  $y : \nu(B_\delta(x) \cap \Lambda_\varepsilon) > 0$
- ▶  $\lambda$ -lemma

# step 3

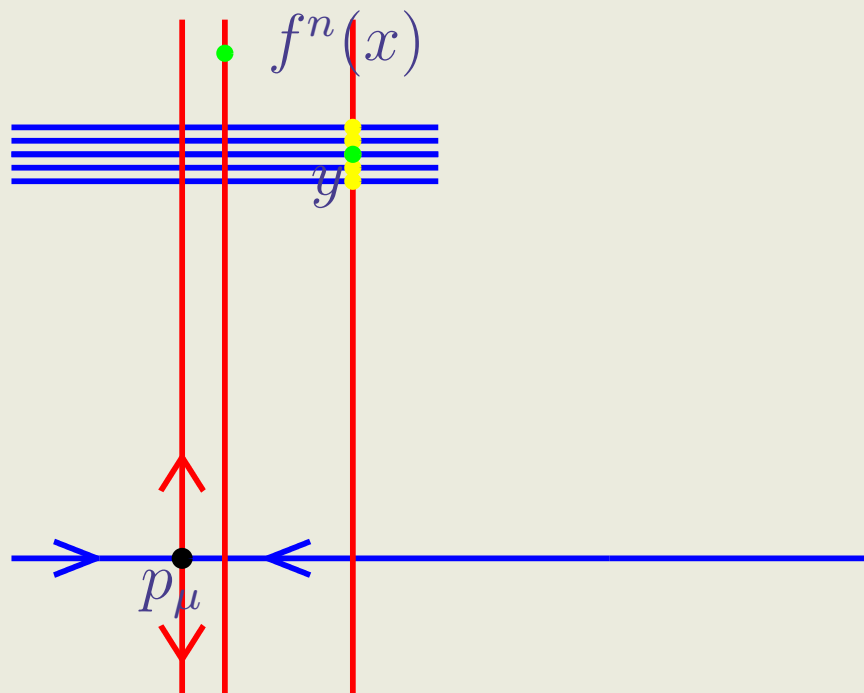

$$\blacktriangleright m_y^u(B_\delta(y) \cap \Lambda_\varepsilon \cap B_\nu) > 0$$

# step 3

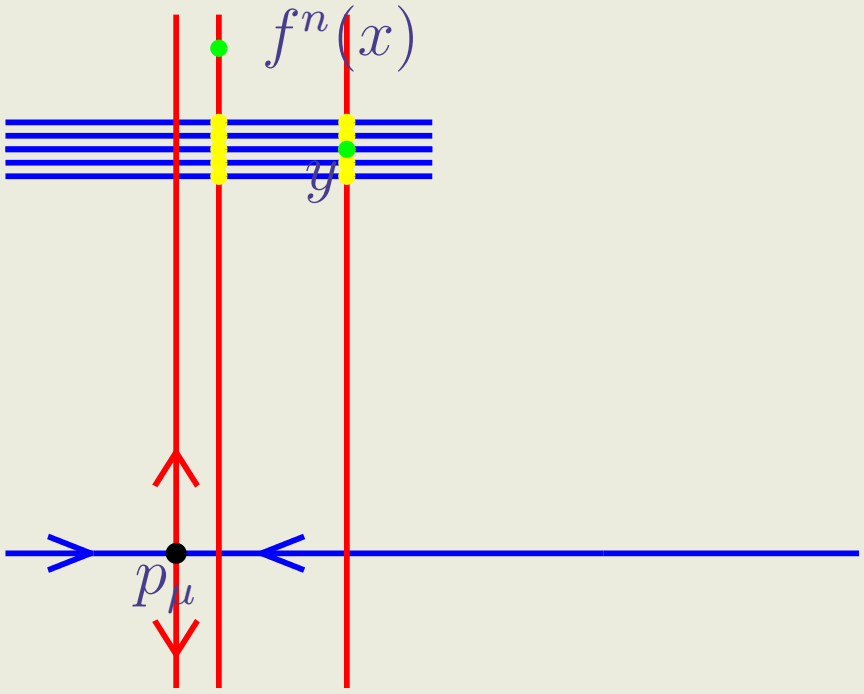

- ▶  $m_y^u(B_\delta(y) \cap \Lambda_\varepsilon \cap B_\nu) > 0$
- ▶  $m_{f^n(x)}^u(B_\nu) > 0$

# step 3

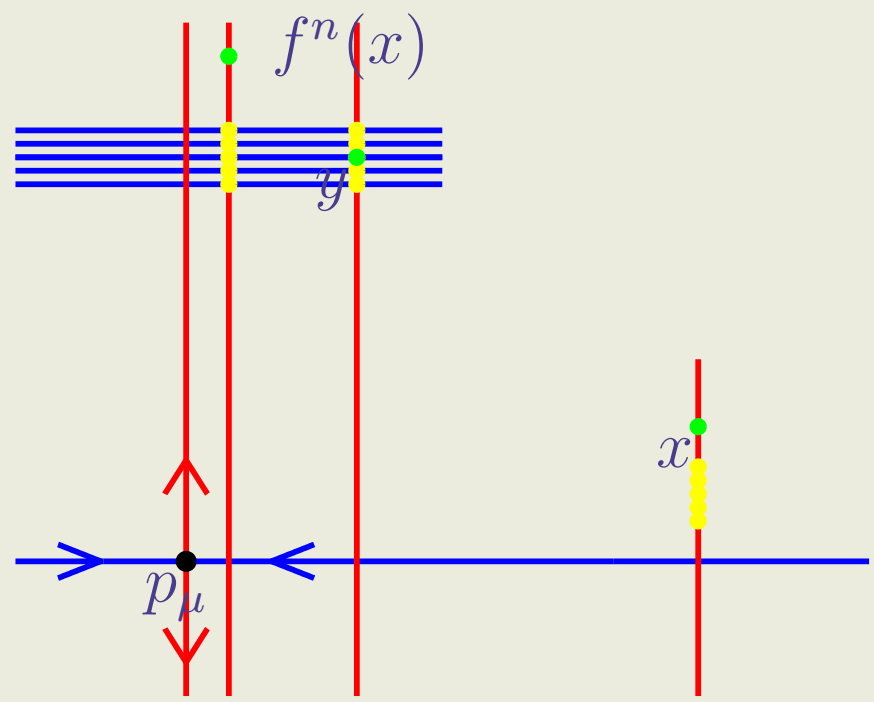

- ▶  $m_y^u(B_\delta(y) \cap \Lambda_\varepsilon \cap B_\nu) > 0$
- ▶  $m_{f^n(x)}^u(B_\nu) > 0$
- ▶  $m_x^u(B_\nu) > 0$

# step 3

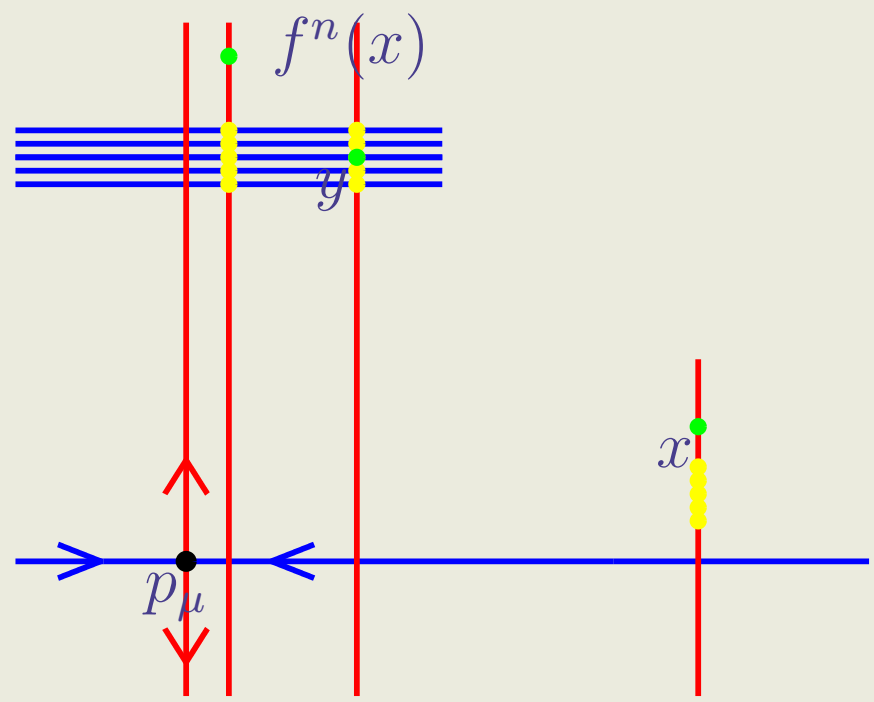

- ▶  $m_y^u(B_\delta(y) \cap \Lambda_\varepsilon \cap B_\nu) > 0$
- ▶  $m_{f^n(x)}^u(B_\nu) > 0$
- ▶  $m_x^u(B_\nu) > 0$
- ▶  $x \in B_\mu$

# step 3

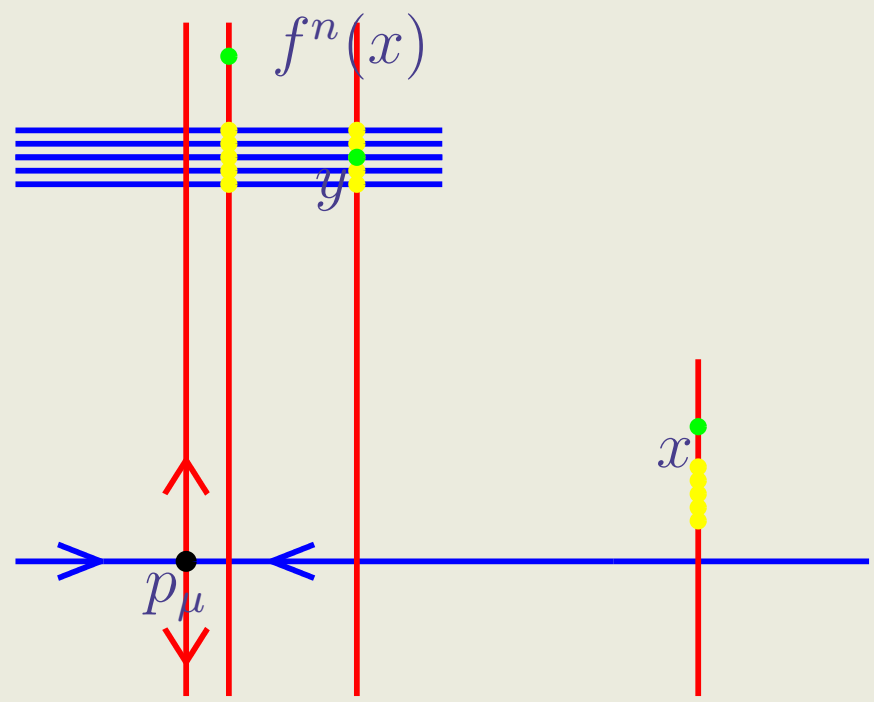

- ▶  $m_y^u(B_\delta(y) \cap \Lambda_\varepsilon \cap B_\nu) > 0$
- ▶  $m_{f^n(x)}^u(B_\nu) > 0$
- ▶  $m_x^u(B_\nu) > 0$
- ▶  $x \in B_\mu$
- ▶  $\mu = \nu$